

POWER RELAY

1 POLE—16 A (CADMIUM FREE CONTACTS TYPE)

VH SERIES

■ FEATURES

- UL, CSA recognized TV-10 rated
- 1 Form A (SPST-NO) contact
- Heavy duty 16 A small power relay with tab-terminals (#250)
- High inrush current and high surge voltage
 - Inrush Current 55 A
 - Surge Strength 7,000 V
- Small package meets high density mounting requirement
- Environmentally friendly cadmium free contact type is available

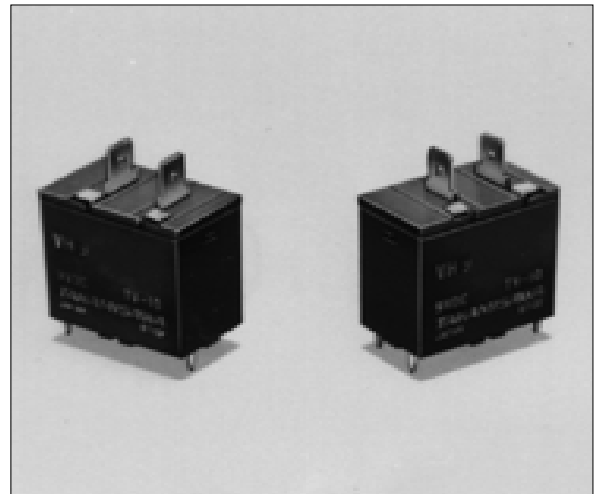

■ ORDERING INFORMATION

[Example] $\frac{VH - 12}{(a) (*) (b)}$

(a)	Series Name	VH: VH Series
(b)	Nominal Voltage	Refer to the COIL DATA CHART

Actual marking omits the hyphen (-) of (*)

■ SAFETY STANDARD AND FILE NUMBERS

UL508, 873 (File No. E56140,E108658)

C22.2 No. 1, No. 14 (File No. LR35579)

Please note that UL/CSA rating may differ from the standard rating.

Please request when the approval markings are required on the cover.

Type	Nominal voltage	Contact rating
VH	5 to 60 VDC	TV-10 120 VAC 1 HP 125 VAC/250 VAC 16 A 125 VAC resistive Pilot duty A 150

■ SPECIFICATIONS

Item		VH	
Contact	Arrangement	1 form A (SPST-NO)	
	Material	Silver-alloy	
	Style	Single	
	Resistance (initial)	Maximum 30 mΩ (at 1 A 6 VDC)	
	Ratings (resistive)	16 A 250 VAC	
	Maximum Carrying Current	20 A	
	Maximum Switching Power	4,000 VA	
	Maximum Switching Voltage	380 VAC	
	Maximum Switching Current	16 A	
	Minimum Switching Load* ¹	100 mA 5 VDC	
Coil	Nominal Power (at 20°C)	0.9 to 1.0 W	
	Operate Power (at 20°C)	0.45 to 0.5 W	
	Operating Temperature	-30°C to +70°C (no frost)	
Time Value	Operate (at nominal voltage)	Maximum 15 ms	
	Release (at nominal voltage)	Maximum 5 ms	
Insulation	Resistance (at 500 VDC)	Minimum 1,000 MΩ	
	Dielectric Strength	between open contacts	1,000 VAC 1 minute
		between coil and contacts	4,000 VAC 1 minute
Surge Strength	7,000 V (at 1.2 × 50 μs)		
Life	Mechanical	5 × 10 ⁶ operations minimum	
	Electrical	2 × 10 ⁵ operations minimum (contact rating)	
Other	Vibration Resistance	Misoperation	10 to 55 Hz (double amplitude of 3 mm)
		Endurance	10 to 55 Hz (double amplitude of 3 mm)
	Shock Resistance	Misoperation	200 m/s ² (11 ±1 ms)
		Endurance	1,000 m/s ² (6 ±1 ms)
	Unit Mass	Approximately 35 g	

*¹ Minimum switching loads mentioned above are reference values. Please perform the confirmation test with the actual load before production since reference values may vary according to switching frequencies, environmental conditions and expected reliability levels.

VH SERIES

COIL DATA CHART

MODEL	Nominal voltage	Coil resistance ($\pm 10\%$)	Must operate voltage	Must release voltage	Nominal power
VH- 5	5 VDC	28 Ω	3.5 VDC	0.25 VDC	0.9 W
VH- 6	6 VDC	40 Ω	4.2 VDC	0.3 VDC	0.9 W
VH- 9	9 VDC	90 Ω	6.3 VDC	0.45 VDC	0.9 W
VH-12	12 VDC	160 Ω	8.4 VDC	0.6 VDC	0.9 W
VH-18	18 VDC	360 Ω	12.6 VDC	0.9 VDC	0.9 W
VH-24	24 VDC	640 Ω	16.8 VDC	1.2 VDC	0.9 W
VH-48	48 VDC	2,300 Ω	33.6 VDC	2.4 VDC	1.0 W
VH-60	60 VDC	3,600 Ω	42.0 VDC	3.0 VDC	1.0 W

Note: All values in the table are measured at 20°C

CHARACTERISTIC DATA

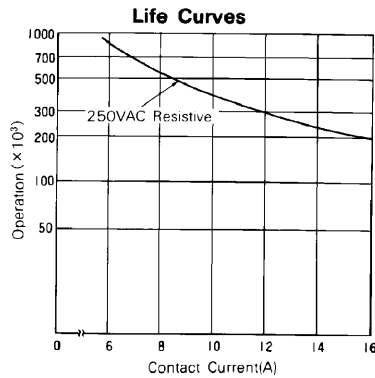
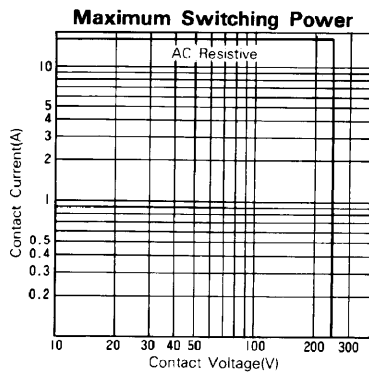
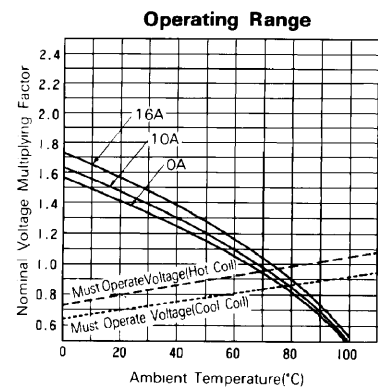
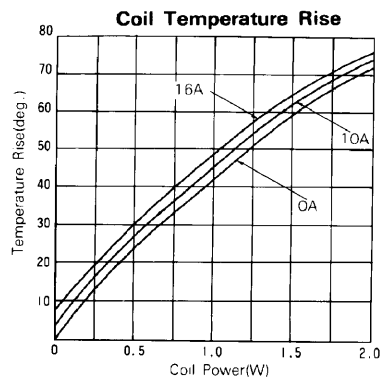
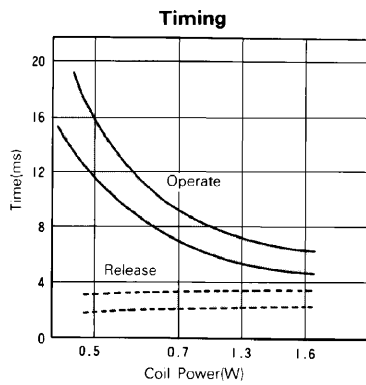

VH SERIES

REFERENCE DATA

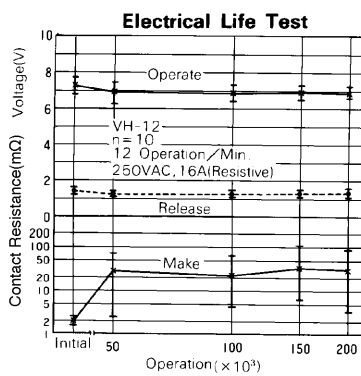
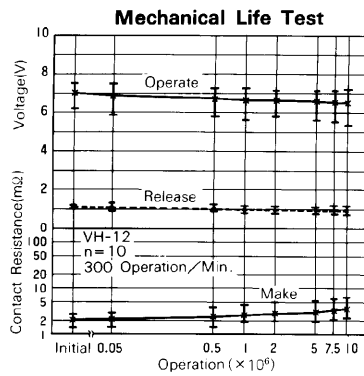
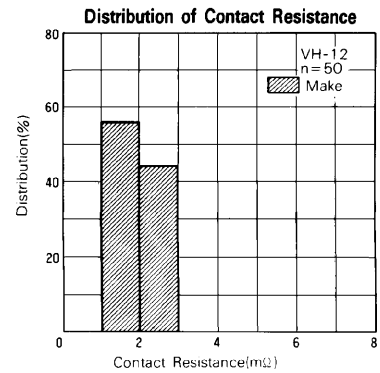
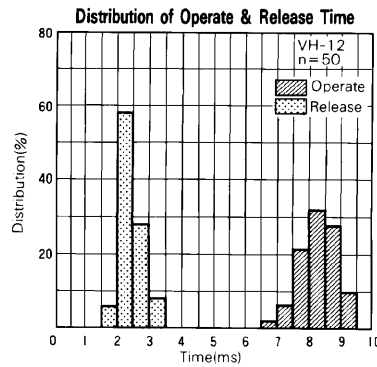
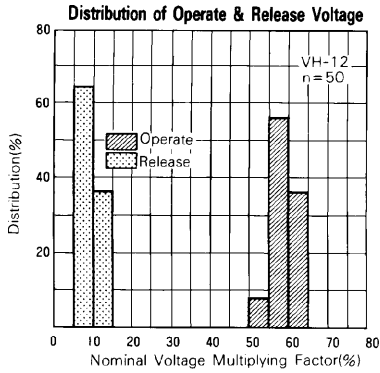

DIMENSIONS

● Dimensions

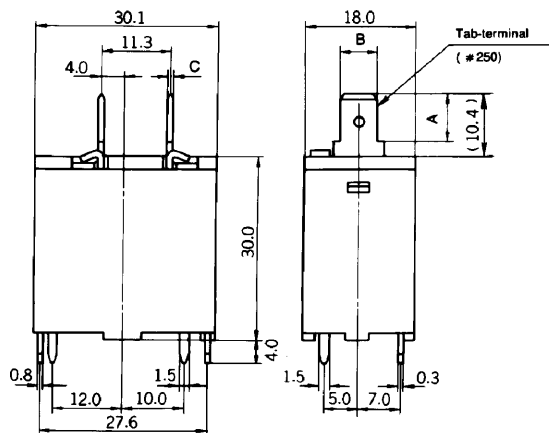

● Schematics (BOTTOM VIEW)

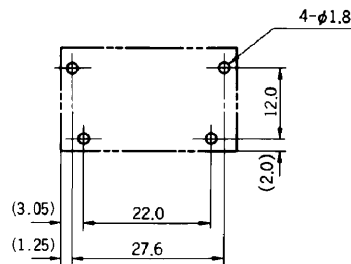

● PC board mounting hole layout

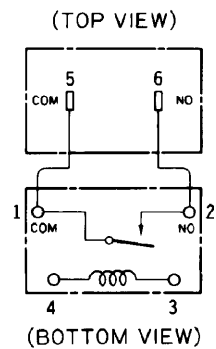

Type	A	B	C
VH	7.95	6.35	0.8

Unit: mm