

# POWER RELAY

## 1 POLE—20, 25, 30 A (HEAVY POWER CONTROL)

### VF SERIES

#### ■ FEATURES

- UL, CSA, VDE recognized TV-15 rated
- 1 Form A (SPST-NO) contact
- Heavy duty 20 to 30 A small power relay
- High inrush current and high surge voltage
  - Inrush current 65 A
  - Surge strength 10,000 V
- Printed circuit coil terminals type available
- Small package meets high density mounting requirement



#### ■ ORDERING INFORMATION

[Example]      VF    B    -    6    H    U  
                   (a)   (b) (\*) (c)   (d)   (e)

(a)	Series Name	VF: VF Series
(b)	Terminal	Nil : Top .....All tab-terminal B : Top .....Tab-terminal (contacts) : Bottom...PCB-terminal (coil and movable contact) D : Top .....Tab-terminal (coil) Screw tight terminal (contacts) P : Top .....Screw tight terminal (contacts) : Bottom...PCB terminal (coil and movable contact)
(c)	Nominal Voltage	Refer to the COIL DATA CHARAT
(d)	Contact Rating	H : 30 A (only VFD, VFP type) M : 25 A L : 20 A
(e)	Standard	U : UL, CSA, VDE rating acquired

Note: Actual marking omits hyphen (-) of (\*)

## ■ SAFETY STANDARD AND FILE NUMBERS

UL508, 873 (File No. E56140)

C22.2 No. 1, No. 14 (File No. LR35579)

VDE 0435

Please note that UL/CSA rating may differ from the standard rating.

Type	Nominal voltage	Contact rating
VF- ( ) L	3 to 60 VDC	TV-15 120 VAC 1 HP 125 VAC/250 VAC 20 A 250 VAC resistive
VF- ( ) M	3 to 60 VDC	TV-15 120 VAC 1.5 HP 250 VAC 25 A 250 VAC resistive
VF- ( ) H	3 to 60 VDC	TV-15 120 VAC 2 HP 250 VAC 30 A 250 VAC resistive

## ■ SPECIFICATIONS

Item		30 A Type	25 A Type	20 A Type	
		VFD, VFP- ( ) H	VF ( ) - ( ) M	VF ( ) - ( ) L	
Contact	Arrangement	1 form A (SPST-NO)			
	Material	Silver alloy			
	Style	Single			
	Resistance (initial)	Maximum 30 mΩ (at 1 A 6 VDC)			
	Rating	Resistive	30 A 250 VAC	25 A 250 VAC	20 A 250 VAC
		Motor	2 HP 250 VAC	1.5 HP 250 VAC	1 HP 250 VAC
	Maximum Carrying Current	30 A	25 A	20 A	
	Maximum Switching Power	7,500 VA	6,250 VA	5,000 VA	
	Maximum Switching Voltage	250 VAC			
	Maximum Switching Current	30 A	25 A	20 A	
Minimum Switching Load*1	100 mA 5 VDC				
Coil	Nominal Power (at 20°C)	1.20 to 1.25 W			
	Operate Power (at 20°C)	1.59 to 0.62 W			
	Operating Temperature	-30°C to +65°C (no frost) (refer to the CHARACTERISTIC DATA)			
Time Value	Operate (at nominal voltage)	Maximum 20 ms			
	Release (at nominal voltage)	Maximum 5 ms			
Insulation	Resistance (at 500 VDC)	Minimum 1,000 MΩ			
	Dielectric Strength	between open contacts	1,200 VAC 1 minute		
		between coil and contacts	4,000 VAC 1 minute		
Surge Strength	10,000 V (at 1.2 × 50 μs)				
Life	Mechanical	5 × 10 <sup>6</sup> operations minimum			
	Electrical (at contact rating)	1 × 10 <sup>5</sup> operations minimum (resistive load)			
		2 × 10 <sup>5</sup> operations minimum (motor load)			
Other	Vibration Resistance	Misoperation	10 to 55 Hz (double amplitude of 1.5 mm)		
		Endurance	10 to 55 Hz (double amplitude of 1.5 mm)		
	Shock Resistance	Misoperation	200 m/s <sup>2</sup> (11 ±1 ms)		
		Endurance	1,000 m/s <sup>2</sup> ( 6 ±1 ms)		
	Weight	Approximately 55 g			

\*1 Minimum switching loads mentioned above are reference values. Please perform the confirmation test with the actual load before production since reference values may vary according to switching frequencies, environmental conditions and expected reliability levels.

## COIL DATA CHART

MODEL			Nominal voltage	Coil resistance (±10%)	Must operate voltage	Must release voltage	Nominal power
30 A Type	25 A Type	20 A Type					
VF (D or P) - 3H	VF ( ) - 3M	VF ( ) - 3L	3 VDC	7.5Ω	2.1 VDC	0.3 VDC	1.2 W
VF (D or P) - 5H	VF ( ) - 5M	VF ( ) - 5L	5 VDC	20 Ω	3.5 VDC	0.5 VDC	1.25 W
VF (D or P) - 6H	VF ( ) - 6M	VF ( ) - 6L	6 VDC	30 Ω	4.2 VDC	0.6 VDC	1.2 W
VF (D or P) - 9H	VF ( ) - 9M	VF ( ) - 9L	9 VDC	67 Ω	6.3 VDC	0.9 VDC	1.2 W
VF (D or P) -12H	VF ( ) -12M	VF ( ) -12L	12 VDC	120 Ω	8.4 VDC	1.2 VDC	1.2 W
VF (D or P) -18H	VF ( ) -18M	VF ( ) -18L	18 VDC	270 Ω	12.6 VDC	1.8 VDC	1.2 W
VF (D or P) -24H	VF ( ) -24M	VF ( ) -24L	24 VDC	480 Ω	16.8 VDC	2.4 VDC	1.2 W
VF (D or P) -48H	VF ( ) -48M	VF ( ) -48L	48 VDC	1,920 Ω	33.6 VDC	4.8 VDC	1.2 W
VF (D or P) -60H	VF ( ) -60M	VF ( ) -60L	60 VDC	3,000 Ω	42.0 VDC	6.0 VDC	1.2 W

Note: All values in the table are measured at 20°C

## CHARACTERISTIC DATA

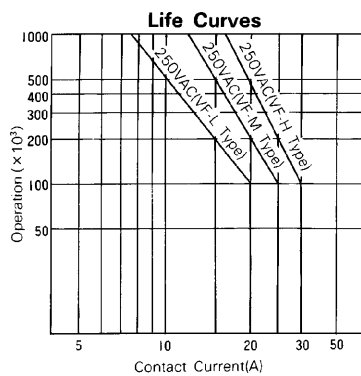
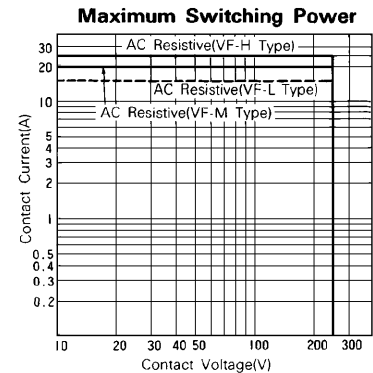
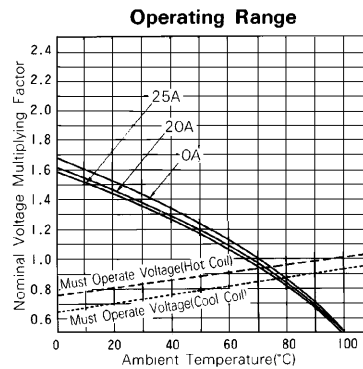
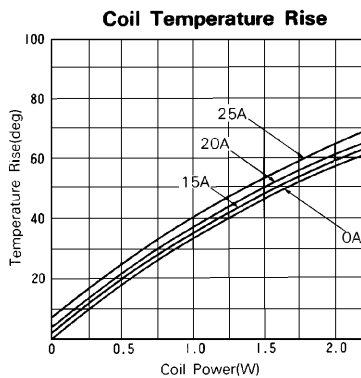

## REFERENCE DATA

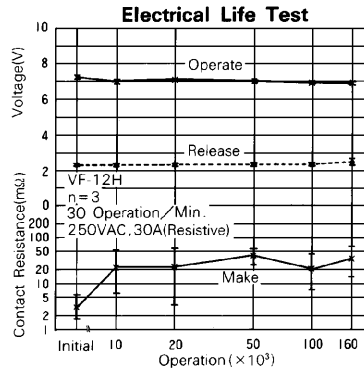
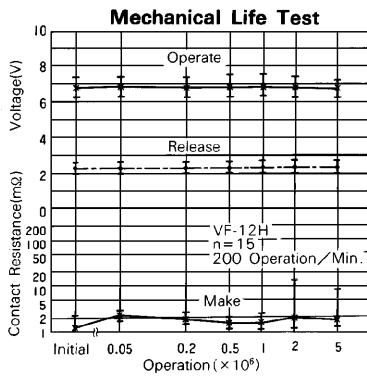
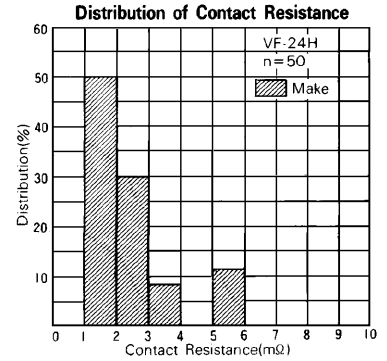
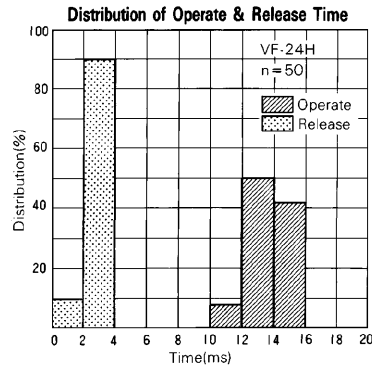
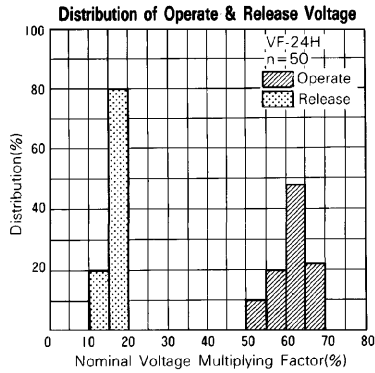

## DIMENSIONS

● Dimensions

● Schematics

● PC board mounting hole layout

VF type

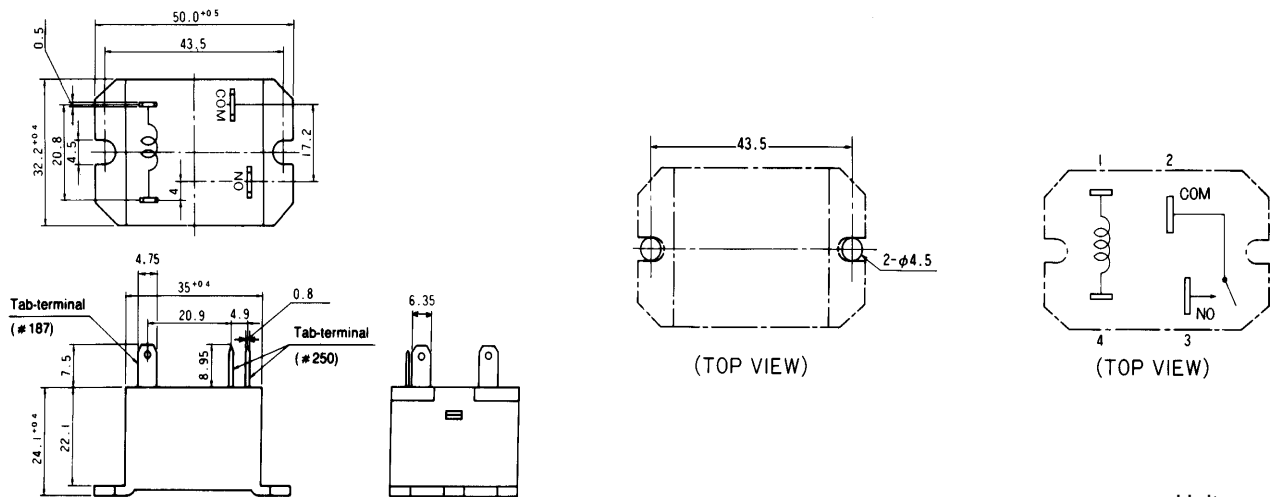

Unit: mm

