

POWER RELAY

1 POLE—5 A (CADMIUM FREE CONTACTS TYPE)

NY SERIES

■ FEATURES

- Ultra slim type with 5 mm thickness
—Good for high density mounting
- Low power consumption and high sensitivity
—Nominal coil power: 120 mW
—Operating power: 54 mW
- UL, CSA, VDE recognized
- Conforms to IEC 1010-1 and 1131-2
- Wide operating range
- SIL pitch terminals
- Plastic sealed type backfilled with nitrogen
- Compatible with solid state I/O module type SN (see page 357) in size and pin (terminal) arrangement
- Environmentally friendly cadmium free contact type is available.

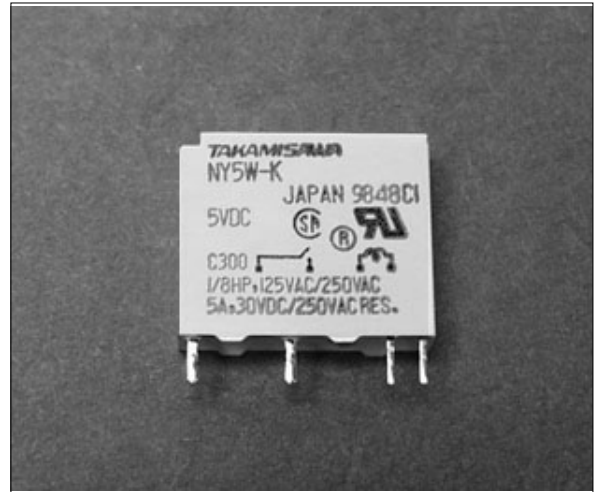

■ ORDERING INFORMATION

[Example] $\frac{NY}{(a)} \frac{P}{(b)} - \frac{12}{(*)} \frac{W}{(c)} - \frac{K}{(d)}$

(a)	Series Name	NY: NY Series
(b)	Terminal Classification	Nil : PC board mounting type P : Socket mounting type
(c)	Nominal Voltage	Refer to the COIL DATA CHART
(d)	Contact	W : Bifurcated type
(e)	Enclosure	K : Plastic sealed type

Note: Actual marking omits the hyphen (-) of (*)

■ SAFETY STANDARD AND FILE NUMBERS

UL508 (File No. E56140)

C22.2 No. 14 (File No. LR35579)

VDE0435

Please note that UL/CSA ratings may differ from the standard ratings.

Nominal voltage	Contact rating
4.5 to 24 VDC	1/8 HP 125 VAC/250 VAC 5 A 30 VDC/250 VAC resistive Pilot duty C 300

■ SPECIFICATIONS

Item		NY	
Contact	Arrangement	1 form A (SPST-NO)	
	Material	Gold overlay silver alloy	
	Style	Bifurcated	
	Resistance (initial)	Maximum 30 mΩ (at 1 A 6 VDC)	
	Rating (resistive)	5 A 250 VAC or 5 A 30 VDC	
	Maximum Carrying Current	5 A	
	Maximum Switching Power	750 VA, 90 W	
	Maximum Switching Voltage	270 VAC, 150 VDC	
	Maximum Switching Current	5 A	
	Minimum Switching Load* ¹	0.1 mA 100 mVDC	
Coil	Nominal Power (at 20°C)	0.12W	
	Operate Power (at 20°C)	0.054 W	
	Operating Temperature	-40°C to +90°C (no frost) (refer to the CHARACTERISTIC DATA)	
Time Value	Operate (at nominal voltage)	Maximum 10 ms	
	Release (at nominal voltage)	Maximum 5 ms	
Insulation	Resistance (at 500 VDC)	Minimum 1,000 MΩ	
	Dielectric Strength	between open contacts	750 VAC 1 minute
		between coil and contacts	3,000 VAC 1 minute
Surge Strength	5,080 V (at 1.2 × 50 μs)		
Life	Mechanical	2 × 10 ⁷ operations minimum	
	Electrical	1.5 × 10 ⁵ operations minimum (at 5A 30VDC) 1.5 × 10 ⁵ operations minimum (at 3 A 120 VAC) 3 × 10 ⁴ operations minimum (at 5 A 250 VAC)	
Other	Vibration Resistance	Misoperation	10 to 55 Hz (double amplitude of 1.5 mm)
		Endurance	10 to 55 Hz (double amplitude of 5.0 mm)
	Shock Resistance	Misoperation	100 m/s ² (11 ± 1 ms)
		Endurance	1,000 m/s ² (6 ± 1 ms)
	Weight	Approximately 3.5 g	

*¹ Minimum switching loads mentioned above are reference values. Please perform the confirmation test with the actual load before production since reference values may vary according to switching frequencies, environmental conditions and expected reliability levels.

COIL DATA CHART

MODEL	Nominal voltage	Coil resistance ($\pm 10\%$)	Must operate voltage	Must release voltage	Nominal power
NY- 4.5 W-K	4.5 VDC	169 Ω	3 VDC	0.45 VDC	120 mW
NY- 5 W-K	5 VDC	208 Ω	3.35 VDC	0.5 VDC	120 mW
NY- 6 W-K	6 VDC	300 Ω	4 VDC	0.6 VDC	120 mW
NY- 9 W-K	9 VDC	675 Ω	6 VDC	0.9 VDC	120 mW
NY- 12 W-K	12 VDC	1,200 Ω	8 VDC	1.2 VDC	120 mW
NY- 18 W-K	18 VDC	2,700 Ω	12.1 VDC	1.8 VDC	120 mW
NY- 24 W-K	24 VDC	4,800 Ω	16.1 VDC	2.4 VDC	120 mW

Note: All values in the table are measured at 20°C

CHARACTERISTIC DATA

Timing

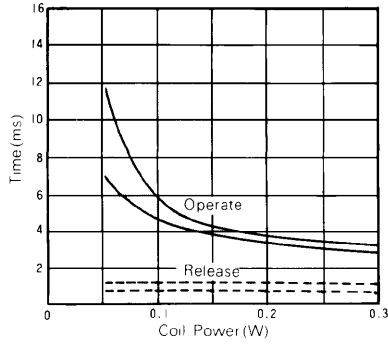

Coil Temperature Rise

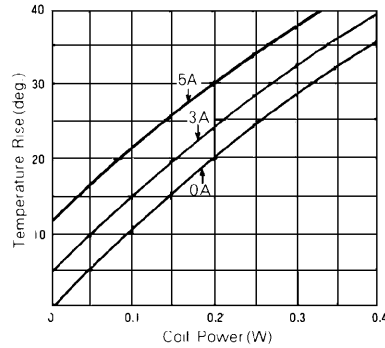

Operating Range

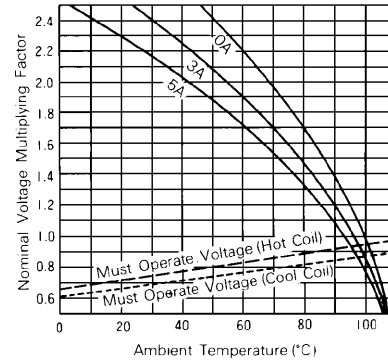

Life Curves

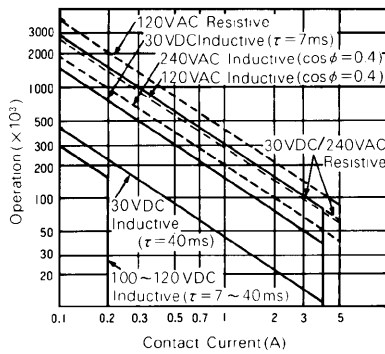

REFERENCE DATA

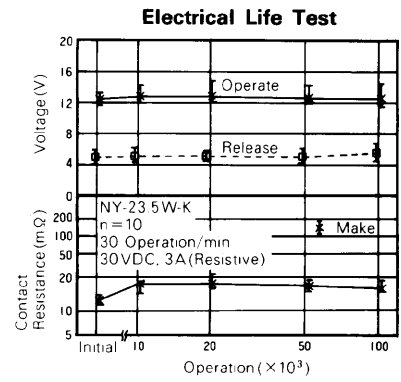
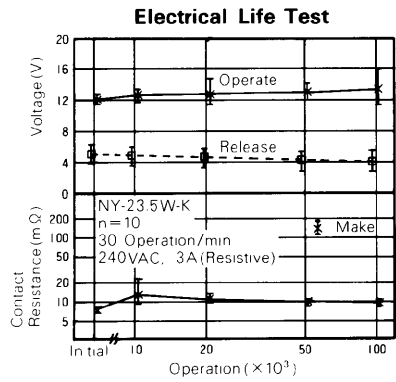
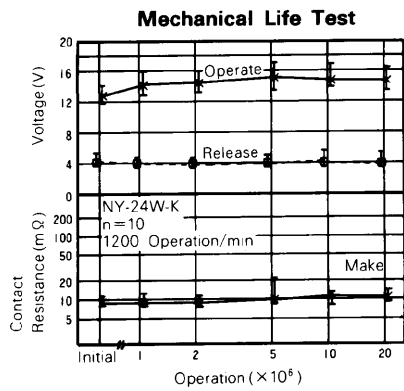
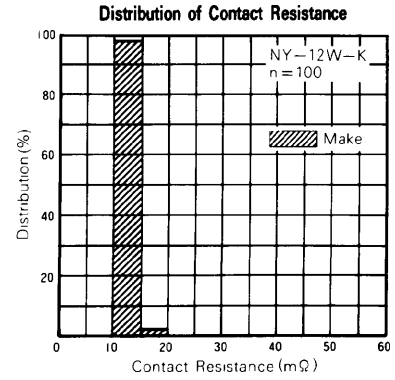
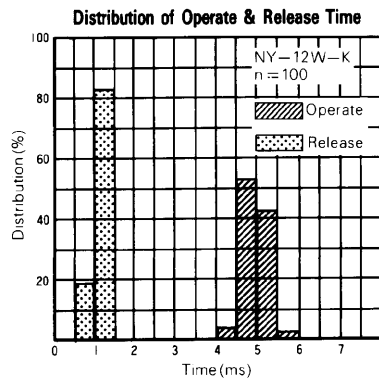
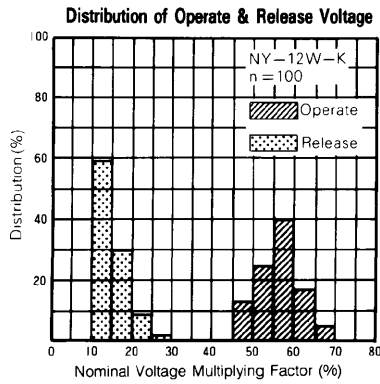

DIMENSIONS

Dimensions

NY type

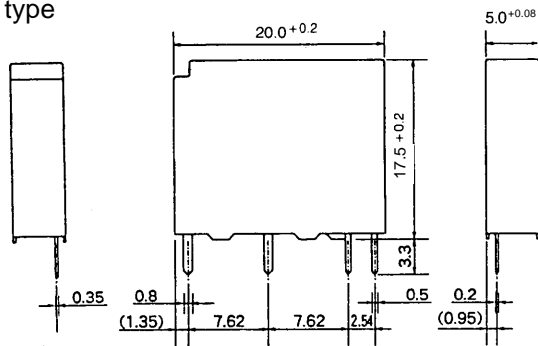

Schematics (BOTTOM VIEW)

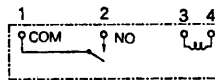

PC board mounting hole layout (BOTTOM VIEW)

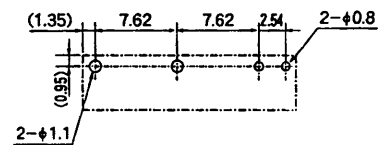

NYP type

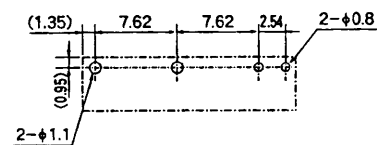
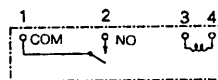
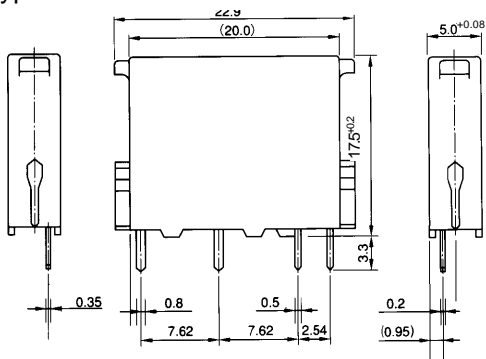

Unit: mm

