

MINIATURE RELAY

1 POLE—1 to 2 A (FOR SIGNAL SWITCHING)

FBR20H SERIES

■ FEATURES

- Low power consumption
High efficiency electromagnetic circuit saves power consumption.
Nominal power consumption: 200 mW
Operate power consumption: 112 mW
- Strong shock resistance
Even with 500 m/s² shock, FBR20H Series relays never miss an operation.
- High dielectric strength type available (conforms to FCC68.302)
Dielectric strength between coil-contact:
AC 1,000 V
Surge strength between coil-contact: 1,500 V
- Easy pattern design
Separate location of drive (coil) and output (contact) terminals allows easy PC board pattern design.
- Formed terminals for temporary mounting
The uniquely designed terminals allow FBR20H Series relays to be mounted temporarily on PC boards.
- UL recognized (File No. E63615)
- Tube packaging

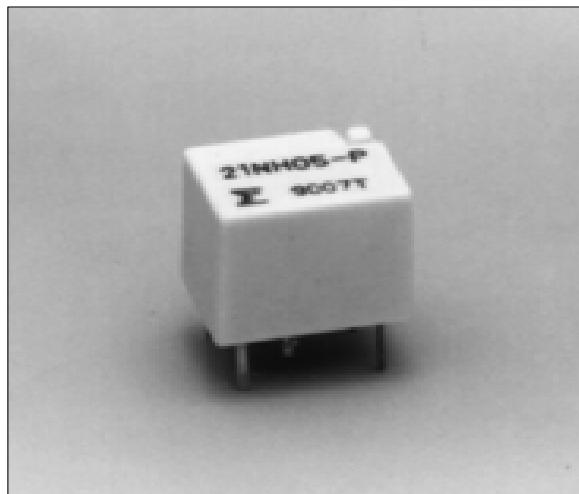

■ ORDERING INFORMATION

[Example] $\frac{\text{FBR21}}{\text{(a)}}$ $\frac{\text{N}}{\text{(b)}}$ $\frac{\text{H12}}{\text{(c)}}$ $\frac{\text{U}}{\text{(d)}}$ $\frac{\text{- P}}{\text{(e)}}$ $\frac{\text{(-02)}}{\text{(f)}}$

(a)	Series Name (Contact Style)	FBR21: FBR20H Series (single contact) FBR22: FBR20H Series (bifurcated contact)
(b)	Enclosure	Nil: Flux free type N: Plastic sealed type
(c)	Nominal Voltage	(Example) H03: 3 VDC H05: 5 VDC H12: 12 VDC (refer to the COIL DATA CHART)
(d)	UL Standard	No designation: standard U: UL114 recognized
(e)	Contact Material	P: Gold-overlay silver-palladium
(f)	Special Type	Nil: Standard 02: High dielectric strength type

Note: The designation name is stamped on the top of the relay case as follows:

(Example) Designation ordered: FBR21H05-P

Stamp: 21H05-P

FBR20H SERIES

■ SAFETY STANDARD AND FILE NUMBERS

UL114 (File No. E63615)

Nominal voltage	Contact rating
1.5 to 24 VDC	1 A 24 VDC resistive 0.5 A 120 VAC resistive

■ SPECIFICATIONS

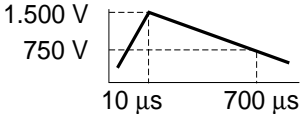
Item		Single contact type	Bifurcated contact type	
Contact	Arrangement	1 form C (SPDT)		
	Material	Gold-overlay silver-palladium		
	Resistance (initial)	Maximum 100 mΩ (at 0.1 A 6 VDC)		
	Rating (resistive)	0.5 A 120 VAC or 1 A 24 VDC (resistive load)		
	Maximum Carrying Current	2 A		
	Maximum Switching Power	60 VA or 24 W		
	Maximum Switching Voltage* ¹	125 V		
	Maximum Switching Current	1 A		
	Minimum Switching Load* ² (reference)	Plastic sealed 1 mA 1 VDC Flux free 1 mA 5 VDC	Plastic sealed 0.1 mA 0.1 VDC Flux free 1 mA 1 VDC	
	Capacitance (reference)	Approximately 2 pF (between coil and contact) Approximately 1 pF (between open contacts)		
Coil	Nominal Power (at 20°C)	Approximately 0.2 W to 0.25 W (24 V coil)		
	Operate Power (at 20°C)	Approximately 0.112 W to 0.14 W maximum (24 V coil)		
	Operating Temperature	-30°C to +70°C (no frost) (refer to the CHARACTERISTIC DATA)		
	Operating Humidity	45 to 85%RH		
Time Value	Operate (at nominal voltage)	Maximum 5 ms		
	Release (at nominal voltage)	Maximum 2 ms		
Insulation	Resistance (initial)	Minimum 100 MΩ (at 500 VDC)		
	Dielectric Strength	between coil and contacts	500 VAC 1 minute (standard) 1,000 VAC 1 minute (high dielectric strength type)	
		between open contacts	500 VAC 1 minute	
Surge Strength (high dielectric strength type)	1,500 V (10 × 700 μs)			
Life	Mechanical	5 × 10 ⁶ operations minimum		
	Electrical (refer to the REFERENCE DATA)	2 × 10 ⁵ operations minimum (at contact rating)		
Other	Vibration Resistance	10 to 300 Hz (double amplitude of 3.0 mm)		
	Shock Resistance	Misoperation	500 m/s ² (11±1 ms)	
		Endurance	1,000 m/s ² (11±1 ms)	
Weight	Approximately 1.7 g			

*¹ If the switching voltage exceeds the rated contact voltage, reduce the current. The current values vary according to the type of load.

*² Values when switching a resistive load at normal room temperature and humidity, and in a clean environment. The minimum switching load varies with the switching frequency and operation environment.

FBR20H SERIES

COIL DATA CHART

MODEL				Nominal voltage	Coil resistance $\pm 10\%$	Nominal current (at nominal voltage) approx.	Must operate voltage	Must release voltage	Maximum allowable voltage	Nominal power	Coil temperature rise
Single contact type		Bifurcated contact type									
Flux free	Plastic sealed	Flux free	Plastic sealed								
FBR21H01-P	FBR21NH01-P	FBR22H01-P	FBR22NH01-P	1.5 VDC	11 Ω	136 mA	75% max. of nominal voltage	10% min. of nominal voltage	200% of nominal voltage	Approx. 200 mW (at nominal voltage)	Approx. 35 deg (at nominal voltage)
FBR21H03-P	FBR21NH03-P	FBR22H03-P	FBR22NH03-P	3 VDC	45 Ω	67 mA					
FBR21H05-P	FBR21NH05-P	FBR22H05-P	FBR22NH05-P	5 VDC	125 Ω	40 mA					
FBR21H06-P	FBR21NH06-P	FBR22H06-P	FBR22NH06-P	6 VDC	180 Ω	33 mA					
FBR21H09-P	FBR21NH09-P	FBR22H09-P	FBR22NH09-P	9 VDC	405 Ω	22 mA					
FBR21H12-P	FBR21NH12-P	FBR22H12-P	FBR22NH12-P	12 VDC	720 Ω	17 mA					
FBR21H18-P	FBR21NH18-P	FBR22H18-P	FBR22NH18-P	18 VDC	1,620 Ω	11 mA					
FBR21H24-P	FBR21NH24-P	FBR22H24-P	FBR22NH24-P	24 VDC	2,300 Ω	10 mA					

Note: All values in the table are measured at 20°C.

CHARACTERISTIC DATA

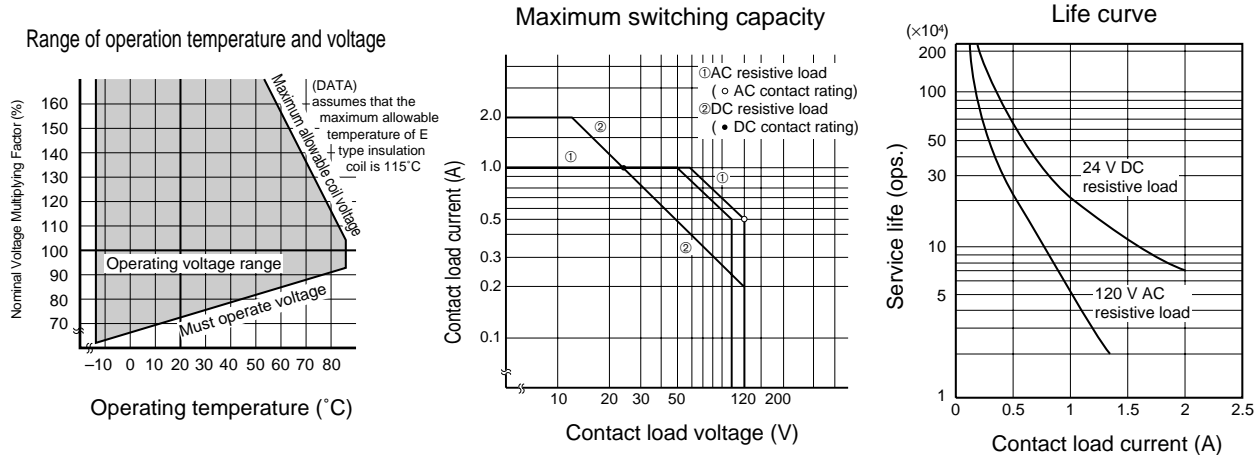

REFERENCE DATA

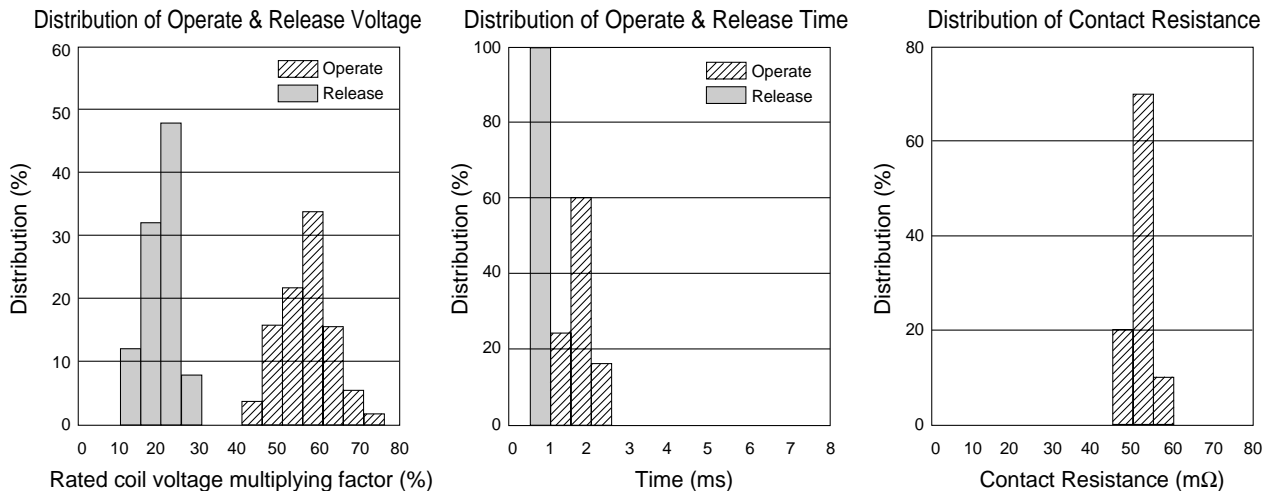

FBR20H SERIES

■ DIMENSIONS

●Dimensions

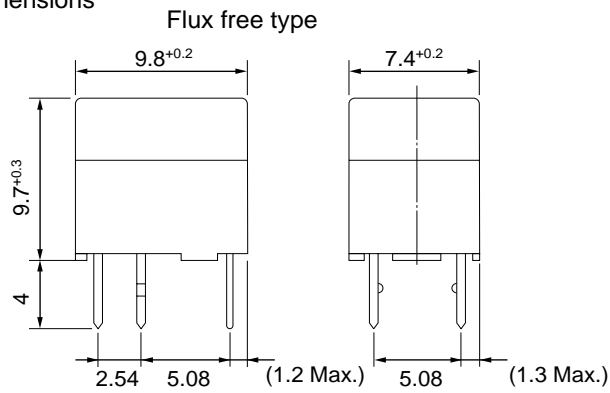

Plastic sealed type

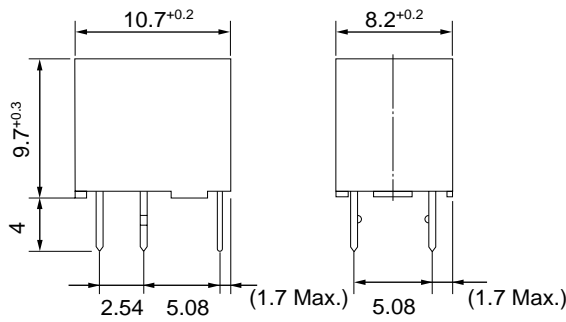

●Tube carrier

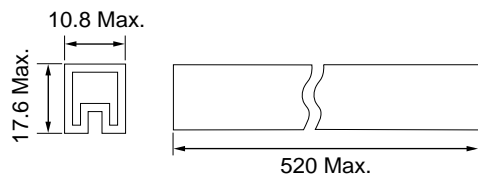

Flux free type:50 pcs/Tube
Plastic sealed type:40 pcs/Tube

●PC board mounting hole layout (BOTTOM VIEW)

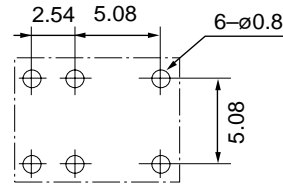

●Schematics (BOTTOM VIEW)

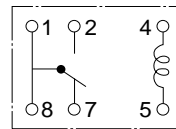

Unit: mm