



TECHNICAL INFORMATION

EQUIVALENT SERIES RESISTANCE OF TANTALUM CAPACITORS

by R.W. Franklin
AVX Limited
Brixham Road, Paignton
Devon, England

Abstract:

The resistive losses which occur with all practical forms of capacitor are made up from several different mechanisms, including resistance in components and contacts, viscous forces within the dielectric and defects producing bypassing current paths.

To express the effect of these various factors on the behavior of an electrolytic capacitor they are lumped together as one term, the equivalent series resistance (ESR).

EQUIVALENT SERIES RESISTANCE OF TANTALUM CAPACITORS

by R.W. Franklin
AVX Limited
Paignton, England

The resistive losses which occur with all practical forms of capacitor are made up from several different mechanisms, including resistance in components and contacts, viscous forces within the dielectric and defects producing bypassing current paths.

To express the effect of these various factors on the behavior of an electrolytic capacitor they are lumped together as one term, the equivalent series resistance (ESR). For electrolytic capacitors this is made up mainly from the resistance of the material contacting the negative side of the dielectric.

For most purposes, the response of a tantalum electrolytic capacitor to a varying signal can be simulated by a series combination of capacitance, resistance and inductance. The values of the capacitance and resistance depend to some extent on the frequency of the signal. However, at any one frequency a value can be quoted as the equivalent series resistance (ESR) and capacitance (ESC) or inductance (ESL). The ESL is partly associated with the body of the capacitor and partly with the leads: the value of the latter part is proportional to the length of lead left on the capacitor when it is mounted in its circuit location. Provided that these leads are kept short, the effect of inductance can be ignored at frequencies below about 100kHz.

Capacitance exists wherever two conductors are separated by an insulator. In the case of a tantalum capacitor the anode is tantalum metal, usually in the form of a porous body of sintered powder — although in the foil style it is either a plain or etched strip of thin foil. The insulator is a thin layer of oxide over the whole surface of the anode, the thickness of the layer being proportional to the rated voltage of the capacitor. The second conductor in the solid tantalum capacitor is a deposit of manganese dioxide covering all the oxide layer. For the foil style, this second conductor is an electrolytic held in a paper tissue separator.

To make connection to the component's terminations other materials are included. For instance, in the solid capacitor the manganese dioxide is covered with carbon and then a metal such as silver. The latter is then joined to the negative lead or case by soldering. In the foil style, there is a second tantalum foil which is wound in with the positive foil and impregnated tissue and thus makes the electrical contact with the electrolyte. The positive connection is made by welding a nickel or steel wire to a tantalum wire on the anode.

The ESR is essentially made up from the resistance of the contacting materials plus the losses in the oxide insulator. At low frequencies, the oxide losses are most significant but, as their contribution decreases inversely with frequency, they eventually become small compared with the contact material resistance.

A typical relationship between ESR and frequency is shown in Fig. 1. The contribution of the oxide losses to the ESR is usually between 500/fC and 1500/fC at room temperature, where f is the frequency measured in hertz and C is the capacitance measured in microfarads.

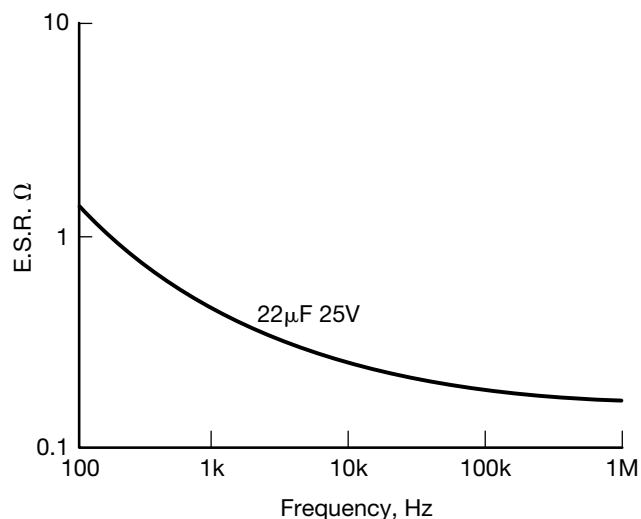

Figure 1. Typical relationship between ESR and frequency.

This part is affected slightly by temperature, the main effect being an increase of, perhaps, two fold from room temperature to 125°C. The bulk of the remainder of the ESR of a solid capacitor is due to resistance in the manganese dioxide and between the manganese dioxide and the carbon. In the foil capacitor it is due to the electrolyte and its interface with the negative foil.

Analysis of the manganese dioxide resistance tends to be complex as both the resistivity and the geometric factors are dependent on manufacturing procedures. Published values of manganese dioxide resistivity for material produced by pyrolysis of the nitrate solution, as in solid capacitors, vary by a factor of at least 10⁴. This is partly due to the effects of the departures from stoichiometry and the size of the individual crystallites. Relating this to the capacitors is complicated by variations in anode porosity, the size of the pores and the percentage fill of the pores with manganese dioxide.

Whereas the oxide losses are essentially constant between capacitors and a production batch, almost always variability of ESR comes from the manganese dioxide deposit. Much effort is expended by capacitor manufacturers to keep this resistance low and repeatable.

Part of the dioxide resistance is on the outside of the porous body and can be considered as a true series resistance. The rest is inside the pores and produces a resistance which increases with distance into the center of the anode.

This effect can be represented as a distributed resistance/capacitance network as in Fig. 2. With such a network, the ESC and ESR decrease with increased frequency (Fig. 3). The frequency at which the main capacitance drop-off occurs depends on the relative

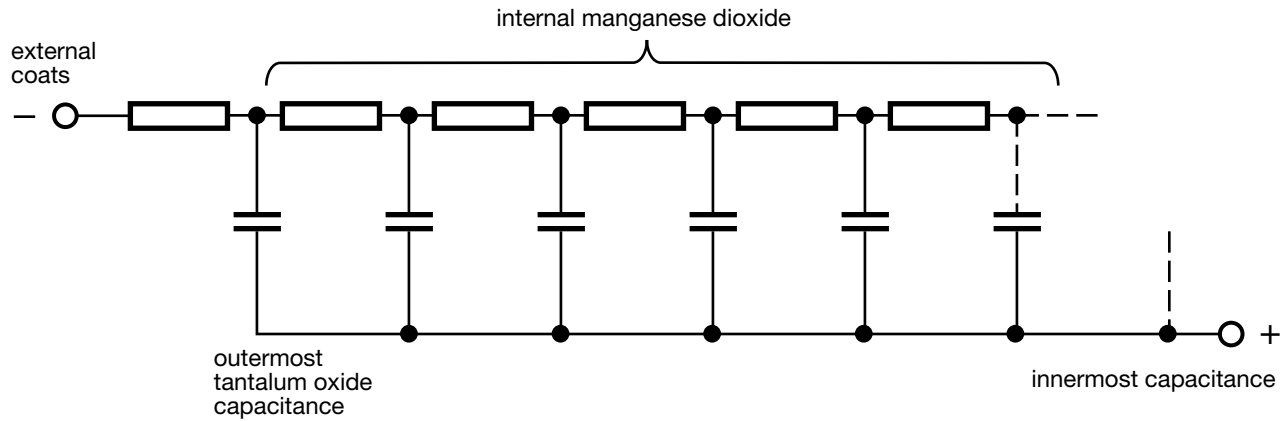

Figure 2. Distributed network of manganese dioxide resistance and tantalum oxide capacitance.

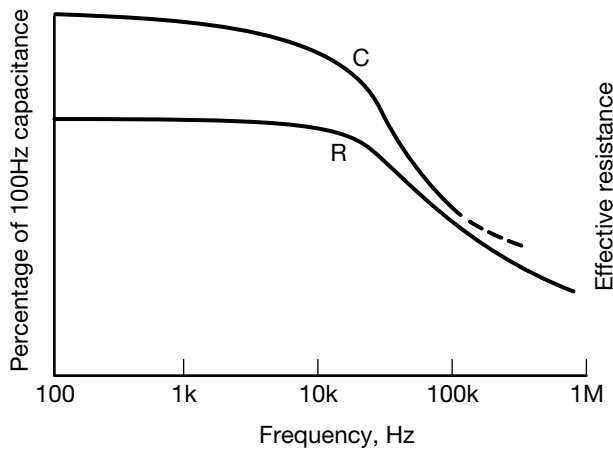

Figure 3. Behavior of distributed network shown in Fig. 2.

levels of capacitance per unit volume and the associated internal resistance. At lower frequencies, the higher the capacitance per unit volume the greater will be the effect unless some compensatory action is taken to reduce the internal resistance. There is a similar, although smaller, effect within the etch pits of an etched foil capacitor.

The resistivity of manganese dioxide decreases with increasing temperature so that its contribution more or less halves as the temperature is raised to 85°C and doubles as it drops to -55°C. To some extent, this counteracts the effect caused by changes in oxide loss with temperature.

At very low frequencies, below 1Hz, two other loss mechanisms need to be considered and these are leakage current and dielectric absorption. The leakage current is equivalent to a parallel resistance (Fig. 4). At any particular frequency this can be represented as a series resistance using the formula:

$$ESR = R_p / [(2 \pi f C_p R_p)^2 + 1]$$

where C_p is the equivalent parallel capacitance in farads and R_p is the parallel resistance of V/I where V is applied DC voltage and I is the leakage current in amps. The C_p term can more or less be equated with the ESC at 120Hz. This contribution to ESR can be approximated to

$$10^5 X / 4 C_{120} f^2 \Omega$$

where X is the leakage current in $\mu A/\mu F V$ and C_{120} is the measured 120Hz capacitance in microfarads. For instance, with a leakage current of 0.001 $\mu A/\mu F V$ for a 10 μF capacitor at 1Hz the contribution to ESR is 2.5 Ω .

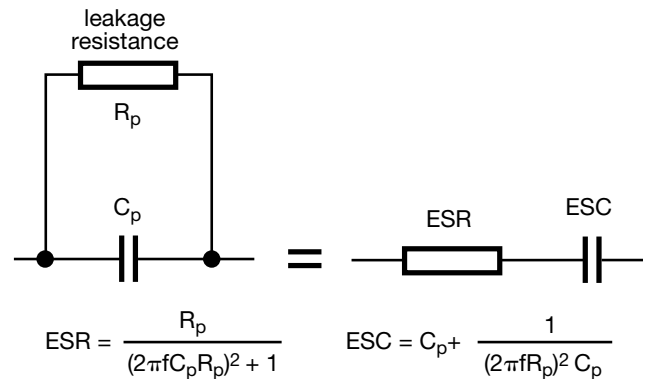

Figure 4. At any frequency the effect of leakage current can be equated with a series combination of C and R.

At 120Hz, this contribution would be a completely negligible amount, 0.00017 Ω . The other low frequency effect, dielectric absorption, can be represented as a collection of capacitor elements joined onto the main capacitor via very high series resistance values (Fig. 5).

Although dielectric absorption is an effect which can be important in some applications because of the charge held in the additional capacitance, the effect on ESR of the total capacitor is relatively small. Each part of the additional capacitance has a very high associated series resistance and this can explain the high time constants of charge movements present in the dielectric absorption process. However, taken overall, the contribution to ESR is unimportant.

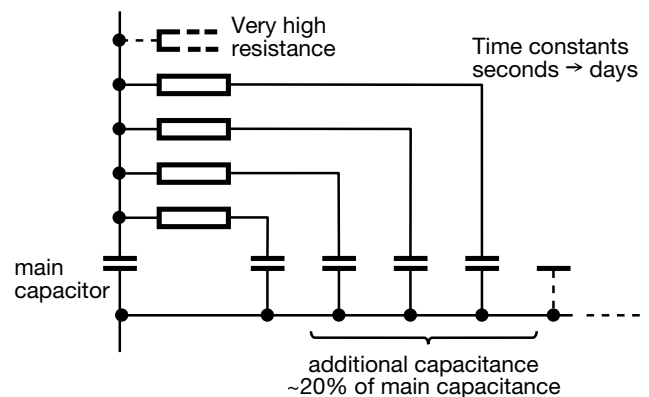

Figure 5. Dielectric absorption.

The resistive effects represented by ESR can affect performance in several ways. First, heat is generated in the capacitor due to I^2R losses. The temperature that the component reaches depends on the balance between this power loss and the rate of heat dissipated from the external surface. By setting a maximum temperature difference between the capacitor and its environment, the ripple rating can be defined.

Secondly, the resistive element increases the impedance above the calculated for the capacitive reactance. This reduces the effectiveness of the capacitor for filtering and decoupling applications.

Thirdly, a phase shift occurs so that the voltage waveform lags the current waveform by less than 90° . This can cause distortion in waveform shaping circuits. Finally, the rate at which charge can be stored in or taken from a capacitor is controlled by the product of C and ESR, the "time constant".

To achieve a low level of ESR for the solid tantalum capacitor, the anode density and aspect ratio and the procedure for depositing manganese dioxide must be matched with each other and then carefully controlled. Over the years, the price of these capacitors in constant money terms has dropped due largely to reduced tantalum content: this has been brought about by introduction of fine powders with their higher surface/weight ratios.

If these finer powders were used at the same density as for the earlier materials, the ESR would be unacceptably high. To prevent this, the anode density has been reduced and the powder is supplied in a form which gives a mixture of coarse and fine pores. It is unlikely that present technologies will lead to any substantial reduction in general ESR levels but, for these circuits where there is a very severe restriction on the maximum ESR allowable, some special selection from standard product may be a possible solution.

Two superconducting electrodes separated by a vacuum would give a loss-free capacitance. However, such a system would have too low a capacitance per unit volume to have any practical application. To improve the capacitance/volume ratio, the vacuum must be replaced by an insulating material of higher dielectric constant. This higher value comes from the alignment of charges associated with electrons, atoms or molecules in the electric field. Such alignment involves motion in a viscous medium and, hence, involves frictional types of losses. The most convenient way of expressing this fact in an equivalent resistance in series with the capacitor (or in terms which are related such as power factor and dissipation factor). Replacing the superconductors by normal electrode materials introduces other resistive losses. These considerations apply to all constructions of electronic capacitor, whatever their dielectric.

A common way of considering the loss factors of an electrolytic capacitor is by lumping all of them into a calculated value of an equivalent series resistance. This value is obtained via measurements of either capacitance plus $\tan \delta$ or impedance plus phase angle.

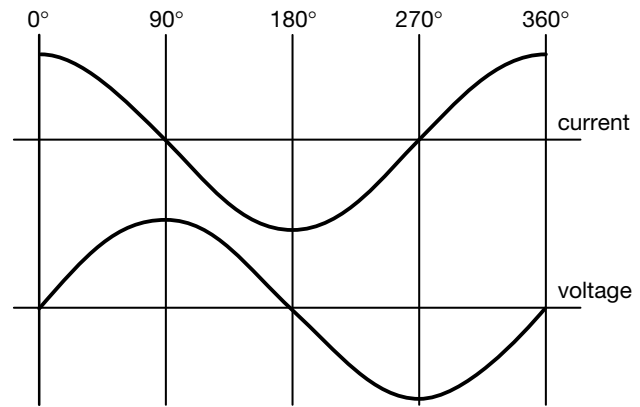

Figure 6. Current and voltage waveforms for a perfect capacitor.

To understand the relationship between these terms, consider first the relationship between the current and voltage waveform when a sinusoidal AC signal is applied to the capacitor. For a pure capacitor, the current waveform leads the voltage by 90° (Fig. 6). For a resistor, the two waveforms would be in phase. In the case of any practical design capacitor the phase angle ϕ would be less than 90° , i.e. between that of a pure capacitor and a pure resistor. The difference between ϕ and 90° is the angle δ . The cosine of ϕ is the power factor: for low values, up to about 0.2 this is almost identical to $\tan \delta$ which is easier to measure. $100 \times \tan \delta$ is the dissipation factor expressed as a percentage. Equations relating to these terms are:

$$\begin{aligned}\phi &= 90^\circ - \delta \\ \text{power factor} &= \cos \phi \\ \text{dissipation factor} &= 100 \tan \delta \\ \tan \delta &= 2\pi fCR\end{aligned}$$

where C and R are the equivalent series components

$$\tan \delta = \frac{\cos \phi}{\sqrt{1 - \cos^2 \phi}}$$

$$\cos \phi = \frac{\tan \delta}{\sqrt{(\tan^2 \delta + 1)}}$$

The use of the terms "power factor", "dissipation factor" and " $\tan \delta$ " for tantalum capacitors is usually limited to frequencies where the inductance is unimportant. The behavior over a wide range of frequencies is covered by impedance together, when required, with phase angle. The impedance Z can be related to the capacitive resistive and inductive terms by the formula:

$$\begin{aligned}Z &= R + j/2\pi fC + j2\pi fL \\ &= \sqrt{[R^2 + 1/(2\pi fC)^2 + (2\pi fL)^2]}\end{aligned}$$

The ESR can be obtained from impedance and phase angle by $R = Z \cos \phi$.

AVX CORPORATION

Myrtle Beach, SC / Tel: 803-448-9411 / FAX: 803-448-1943

Vancouver, WA / Tel: 206-696-2840 / FAX: 206-695-5836

Olean, NY / Tel: 716-372-6611 / FAX: 716-372-6316

Raleigh, NC / Tel: 919-878-6200 / FAX: 919-878-6462

Biddeford, ME / Tel: 207-282-5111 / FAX: 207-283-1941

AVX Limited, Fleet, Hants, England / Tel: (01252) 770000 / FAX: (01252) 770001

AVX S.A., France / Tel: (1) 6918 4600 / FAX: (1) 6928 7387

AVX GmbH, Germany / Tel: 08131 9004-0 / FAX: 08131 9004-44

AVX s.r.l., Milano, Italy / Tel: 02-665 00116 / FAX: 02-614 2576

AVX/Kyocera (HK) Ltd. / Tel: 852-363-3303 / FAX: 852-765-8185

AVX/Kyocera (Singapore) Pte. Ltd. / Tel: (65) 258-2833 / FAX: (65) 258-8221

AVX Israel Ltd. / Tel: 972-957-3873 / FAX: 972-957-3853

AVX/Kyocera Corp. / Tel: 75-593-4518 / FAX: 75-501-4936

S-RTC2.5M895-R