

**AVX**  
A KYOCERA GROUP COMPANY

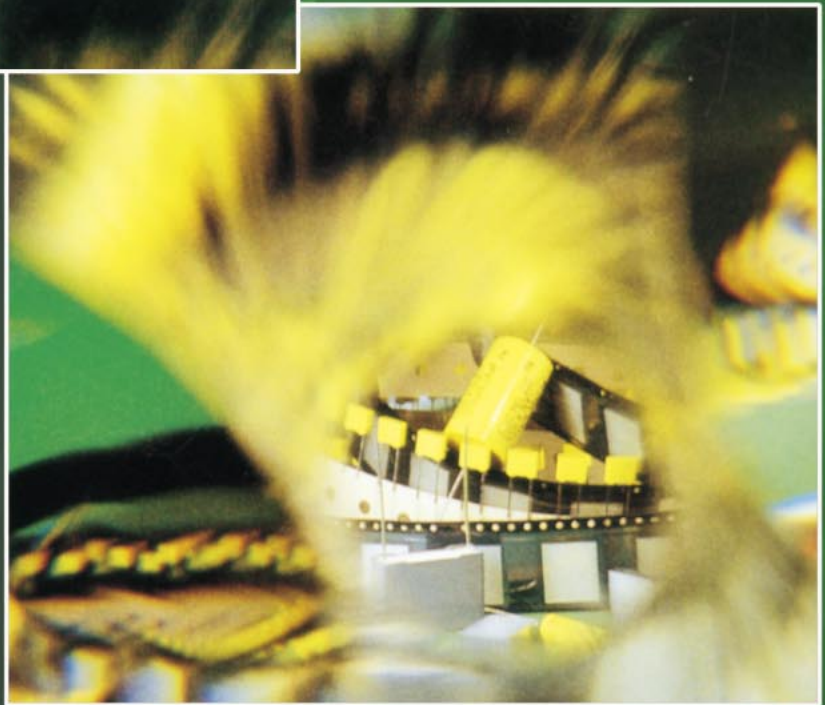

# **TPC Film Chip Capacitors**

# Film Chip Capacitors

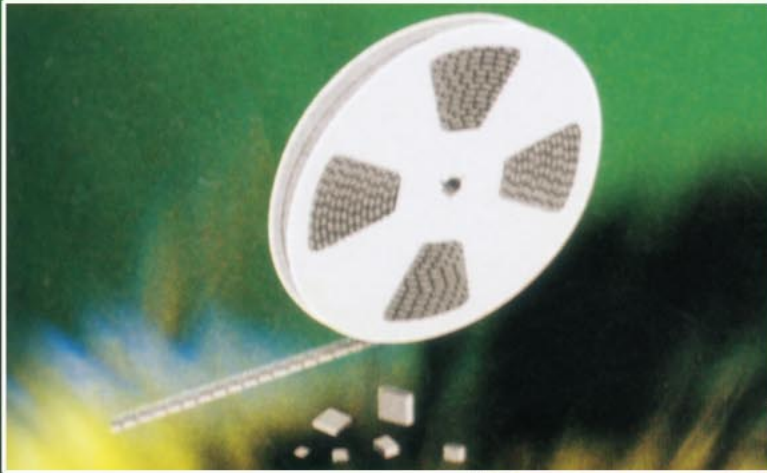

## Contents

---

<b>CF Series</b> .....	<b>2</b>
<b>Standardized Range PET H.T. (CF--2)</b> .....	<b>3</b>
<b>Standardized Range PEN (CF--7)</b> .....	<b>7</b>
<b>Standardized Range PET H.T. (CF--2) / PEN (CF--7)</b> .....	<b>11</b>
<b>Original Range (Non-Standardized) PEN (CF--7)</b> .....	<b>12</b>

As we are anxious that our customers should benefit from the latest developments in the technology and standards, AVX reserves the right to modify the characteristics published in this brochure.

NOTICE: Specifications are subject to change without notice. Contact your nearest AVX Sales Office for the latest specifications. All statements, information and data given herein are believed to be accurate and reliable, but are presented without guarantee, warranty, or responsibility of any kind, expressed or implied. Statements or suggestions concerning possible use of our products are made without representation or warranty that any such use is free of patent infringement and are not recommendations to infringe any patent. The user should not assume that all safety measures are indicated or that other measures may not be required. Specifications are typical and may not apply to all applications.

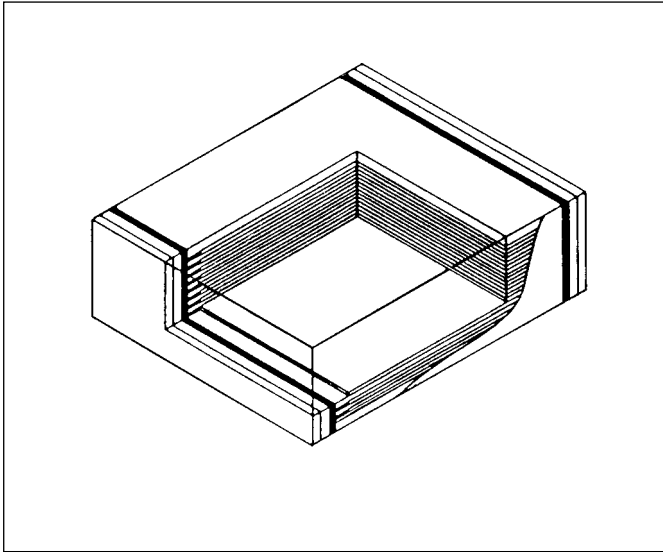

### DESCRIPTION

Film chip capacitor using a naked and stacked construction with both metallized PEN or High Temperature PET.  
"Standardized range"

### GENERAL CHARACTERISTICS

Capacitance range (E6 series)	1 nF to 4.7 $\mu$ F
Tolerance on capacitance	$\pm 5\%$ , $\pm 10\%$ (tighter tolerance upon request)
Rated voltage range $U_r$	63 V to 250 V
Temperature range	-55°C to +125°C with voltage derating of 1.25%/°C between 105°C and 125°C
Climatic category	55/125/56
Surge voltage	1.4 $U_r$ 2s
Dissipation factor	$< 80 \cdot 10^{-4}$ @ 1 kHz
Soldering methods	IR or vapor phase reflow

### ADVANTAGES

- Use of high temperature dielectric films makes these capacitors suitable for IR or vapor phase reflow processes. This chip is built without specific encapsulation.
- The intrinsic elasticity of the dielectric film allows an excellent compatibility of the capacitor with all types of material for printed circuit boards.
- The self-healing property of film technology results in safe open circuit failure mode and better overall reliability.
- Excellent thermal shock resistance.
- Low dissipation factor, ESR and ESL.

# Film Chip Capacitors



## Standardized Range PET H.T. (CF--2)

### DESCRIPTION

Use of high temperature PET (polyethylene terephthalate) as dielectric.

New range available in six "standardized" \*case sizes from 1812 to 6054.

### CAPACITANCE AND VOLTAGE RANGE

millimeters (inches)

DC Rated Voltage (105°C / 125°C)									
Capacitance	63 V / 47 V		100 V / 75 V		160 V / 120 V		250 V / 187 V		Capacitance Code
	Case Code	H max	Case Code	H max	Case Code	H max	Case Code	H max	
1 nF	03	1.5 (.059)	03	1.5 (.059)	03	1.5 (.059)	03	1.5 (.059)	0102
1.5	03	1.5 (.059)	03	1.5 (.059)	03	1.5 (.059)	03	1.5 (.059)	0152
2.2	03	1.5 (.059)	03	1.5 (.059)	03	1.5 (.059)	03	1.5 (.059)	0222
3.3	03	1.5 (.059)	03	1.5 (.059)	03	1.5 (.059)	03	1.5 (.059)	0332
4.7	03	1.5 (.059)	03	1.5 (.059)	03	1.5 (.059)	03	1.5 (.059)	0472
6.8	03	1.5 (.059)	03	1.5 (.059)	03	1.5 (.059)	03	1.5 (.059)	0682
10	03	1.5 (.059)	03	1.5 (.059)	03	1.5 (.059)	03	1.5 (.059)	0103
15	03	1.5 (.059)	03	1.5 (.059)	03	1.5 (.059)	03	2.5 (.098)	0153
22	03	1.5 (.059)	03	1.5 (.059)	03	2.0 (.079)	04	2.4 (.094)	0223
33	03	1.5 (.059)	03	1.5 (.059)	03	2.5 (.098)	04	2.4 (.094)	0333
47	03	2.0 (.079)	03	2.0 (.079)	04	2.4 (.094)	04	3.0 (.118)	0473
68	03	2.0 (.079)	03	3.1 (.122)	04	3.5 (.138)	04	4.5 (.177)	0683
100	03	2.0 (.079)	03	3.1 (.122)	04	3.5 (.138)	05	4.0 (.157)	0104
150	03	3.1 (.122)	04	3.0 (.118)	05	5.7 (.224)	05	5.7 (.224)	0154
220	03	3.1 (.122)	04	4.5 (.177)	05	5.0 (.197)	16	4.0 (.157)	0224
330	04	3.5 (.138)	04	4.5 (.177)	16	4.0 (.157)	16	5.8 (.228)	0334
470	04	4.0 (.157)	05	5.7 (.224)	17	3.8 (.150)	17	5.0 (.197)	0474
680	04	4.5 (.177)	05	5.7 (.224)	17	5.0 (.197)	18	4.4 (.173)	0684
1 µF	05	5.0 (.197)	16	4.8 (.189)	18	4.4 (.173)	18	5.7 (.224)	0105
1.5	17	5.0 (.197)	17	5.0 (.197)	18	6.5 (.256)			0155
2.2	17	5.5 (.217)	17	5.5 (.217)					0225
3.3	18	5.0 (.197)	18	5.0 (.197)					0335
4.7	18	5.7 (.224)	18	5.7 (.224)					0475

millimeters (inches)

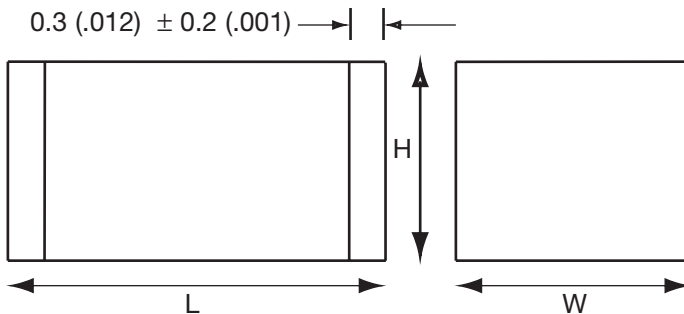

Case Code	Equivalent Size	L	W
03	1812	4.5 ± 0.5 (.177±.020)	3.2 ± 0.5 (.126±.020)
04	2220	5.7 ± 0.5 (.224±.020)	5.0 ± 0.5 (.197±.020)
05	2824	7.1 ± 0.5 (.280±.020)	6.1 ± 0.5 (.240±.020)
16	4030	10.2 ± 0.6 (.401±.024)	7.6 ± 0.8 (.299±.031)
17	5040	12.7 ± 0.6 (.50±.024)	10.2 ± 0.8 (.401±.031)
18	6054	15.2 ± 0.6 (.598±.024)	13.7 ± 0.8 (.539±.031)

\* "Standardized Range": Range available from several film capacitors suppliers.

# Film Chip Capacitors

## Standardized Range PET H.T. (CF--2)



### ELECTRICAL CHARACTERISTICS (TYPICAL VALUES)

**CAPACITANCE**

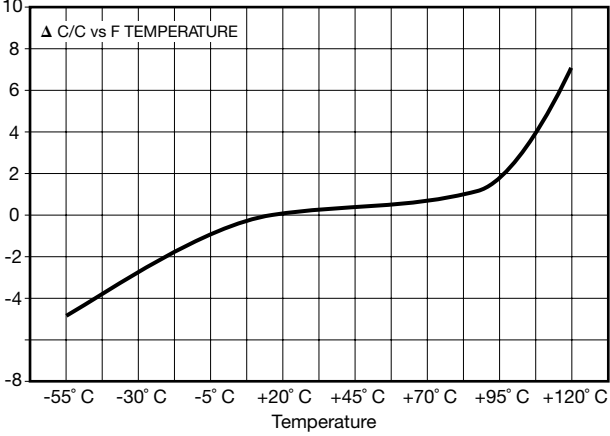

**DISSIPATION FACTOR**

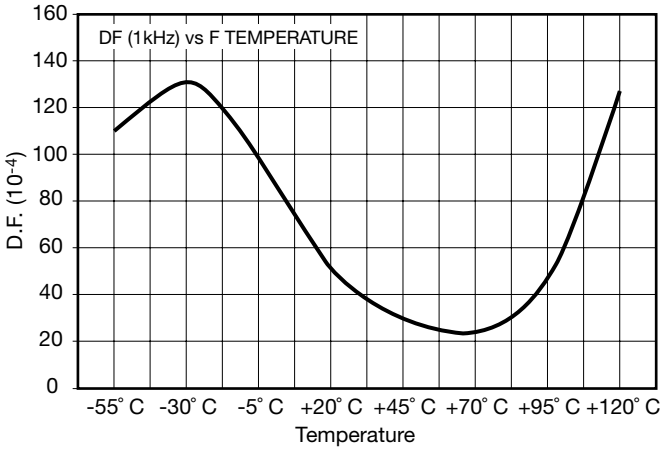

**INSULATION RESISTANCE**

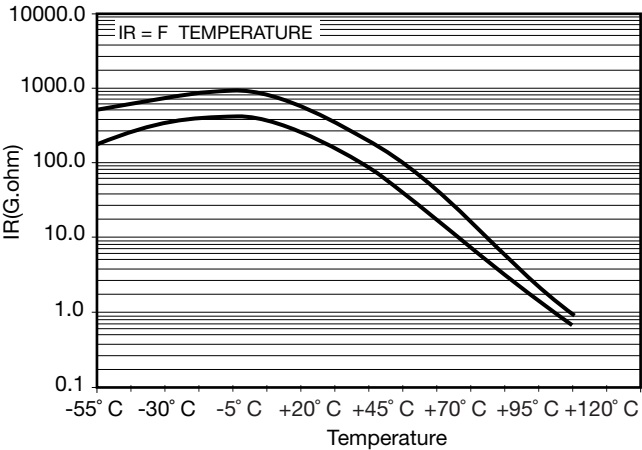

Minimum Insulation Resistance at 20°C	
C 0.33 μF	C > 0.33 μF
IR > 1000 MΩ	IR.C > 400 sec

Measuring conditions: the insulation resistance value is measured 1 minute after a voltage of 10 V for  $U_r < 100$  V and 100 V for  $U_r \geq 100$  V has been applied between terminations.

# Film Chip Capacitors

## Standardized Range PET H.T. (CF--2)



### FREQUENCY CHARACTERISTICS (TYPICAL VALUES)

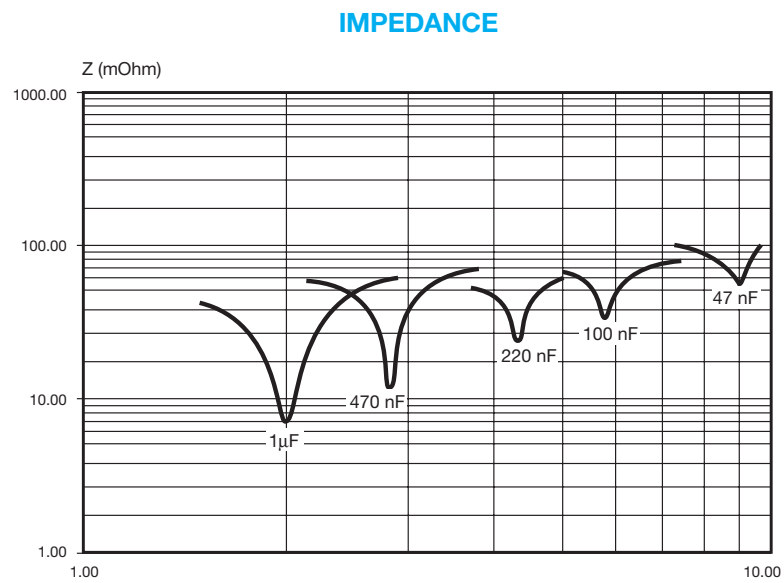
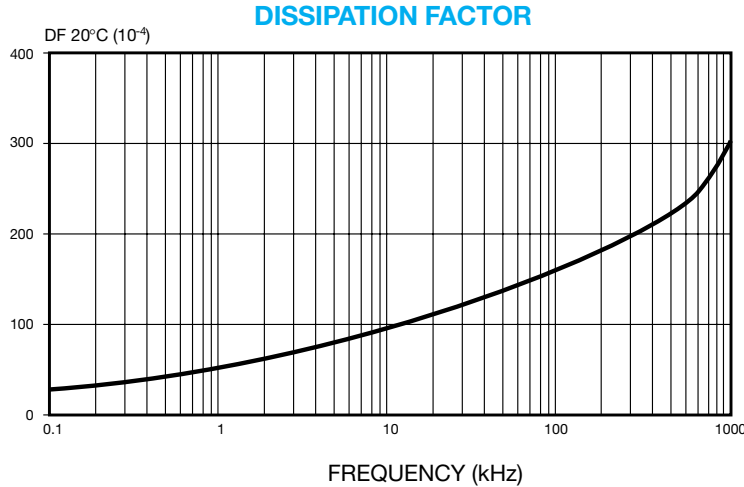
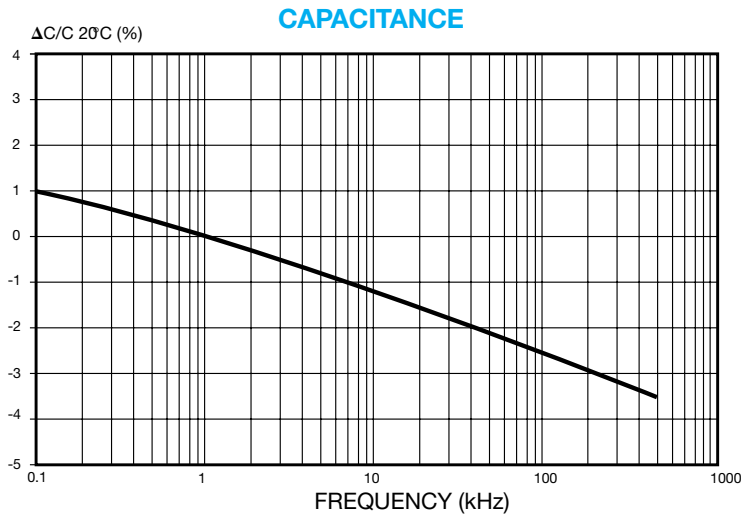

# Film Chip Capacitors



## Standardized Range PET H.T. (CF--2)

### PACKAGING

The CF Series is available in bulk or tape and reel for automatic insertion.

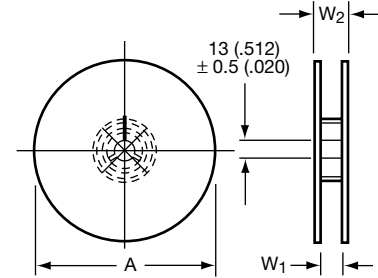
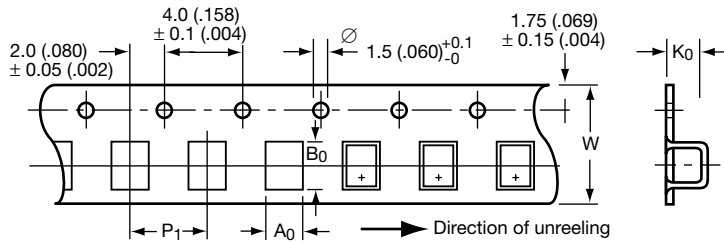

### TAPE AND REEL PACKAGING CODES

Packaging Codes					
Capacitance	Rated Voltage				Capacitance code
	63 V	100 V	160 V	250 V	
1 to 10 nF	A1	A1	A1	A1	0102-0103
15	A1	A1	A1	A3	0153
22	A1	A1	A2	B1	0223
33	A1	A1	A3	B1	0333
47	A2	A2	B1	B2	0473
68	A2	A4	B3	B5	0683
100	A2	A4	B3	C1	0104
150	A4	B2	C3	C3	0154
220	A4	B5	C2	D1	0224
330	B3	B5	D1	D3	0334
470	B4	C3	E1	E2	0474
680	B5	C3	E2	F1	0684
1 µF	C2	D2	F1	F3	0105
1.5	E2	E2	F4		0155
2.2	E3	E3			0225
3.3	F2	F2			0335
4.7	F3	F3			0475

#### Tape and reel characteristics:

In accordance with IEC 286 and EIA 481  
Material used:

Carrier tape: Antistatic Polycarbonate.

Cover tape: Polyester.

Reel: Recyclable polyester or cardboard.

Parts in bulk or on reel are packed in hermetically sealed plastic bags.

(Recommendation: Once the bag is open the capacitors should be kept in a dry atmosphere until soldering).

### TAPE AND REEL CHARACTERISTICS AND PACKAGING QUANTITIES

Case size	Bulk Qty/bag	Reel tape pack code	Reel tape Qty/reel	Tape dimensions			Reel dimensions		
				W ± 0.3	P1 ± 0.1	Ko	A ± 2	W1 +2 -0	W2 max
1812	1500	A1	1500	12.0 (.472)	8.0 (.315)	1.6 (.063)	180 (7.09)	12.4 (.488)	18.4 (.724)
		A2	1200	12.0 (.472)	8.0 (.315)	2.1 (.083)	180 (7.09)	12.4 (.488)	18.4 (.724)
		A3	900	12.0 (.472)	8.0 (.315)	2.6 (.102)	180 (7.09)	12.4 (.488)	18.4 (.724)
		A4	700	12.0 (.472)	8.0 (.315)	3.2 (.126)	180 (7.09)	12.4 (.488)	18.4 (.724)
1812	1500	A1	5800	12.0 (.472)	8.0 (.315)	1.6 (.063)	330 (13.0)	12.4 (.488)	22.0 (.866)
		A2	4500	12.0 (.472)	8.0 (.315)	2.1 (.083)	330 (13.0)	12.4 (.488)	22.0 (.866)
		A3	3600	12.0 (.472)	8.0 (.315)	2.6 (.102)	330 (13.0)	12.4 (.488)	22.0 (.866)
		A4	2900	12.0 (.472)	8.0 (.315)	3.2 (.126)	330 (13.0)	12.4 (.488)	22.0 (.866)
2220	1500	B1	3800	12.0 (.472)	8.0 (.315)	2.5 (.098)	330 (13.0)	12.4 (.488)	22.0 (.866)
		B2	3000	12.0 (.472)	8.0 (.315)	3.1 (.122)	330 (13.0)	12.4 (.488)	22.0 (.866)
		B3	2600	12.0 (.472)	8.0 (.315)	3.6 (.141)	330 (13.0)	12.4 (.488)	22.0 (.866)
		B4	2300	12.0 (.472)	8.0 (.315)	4.1 (.161)	330 (13.0)	12.4 (.488)	22.0 (.866)
		B5	1900	12.0 (.472)	8.0 (.315)	4.6 (.181)	330 (13.0)	12.4 (.488)	22.0 (.866)
2824	1000	C1	2100	16.0 (.630)	8.0 (.315)	4.1 (.161)	330 (13.0)	16.4 (.646)	25.0 (.984)
		C2	1700	16.0 (.630)	8.0 (.315)	5.1 (.200)	330 (13.0)	16.4 (.646)	25.0 (.984)
		C3	1500	16.0 (.630)	8.0 (.315)	5.8 (.228)	330 (13.0)	16.4 (.646)	25.0 (.984)
4030	500	D1	1400	16.0 (.630)	12.0 (.472)	4.1 (.161)	330 (13.0)	16.4 (.646)	25.0 (.984)
		D2	1200	16.0 (.630)	12.0 (.472)	4.9 (.193)	330 (13.0)	16.4 (.646)	25.0 (.984)
		D3	1000	16.0 (.630)	12.0 (.472)	5.9 (.232)	330 (13.0)	16.4 (.646)	25.0 (.984)
5040	300	E1	1100	24.0 (.945)	16.0 (.630)	3.9 (.154)	330 (13.0)	24.4 (.960)	34.0 (1.34)
		E2	800	24.0 (.945)	16.0 (.630)	5.1 (.200)	330 (13.0)	24.4 (.960)	34.0 (1.34)
		E3	800	24.0 (.945)	16.0 (.630)	5.6 (.220)	330 (13.0)	24.4 (.960)	34.0 (1.34)
6054	300	F1	600	24.0 (.945)	24.0 (.945)	4.5 (.177)	330 (13.0)	24.4 (.960)	34.0 (1.34)
		F2	500	24.0 (.945)	24.0 (.945)	5.1 (.200)	330 (13.0)	24.4 (.960)	34.0 (1.34)
		F3	500	24.0 (.945)	24.0 (.945)	5.8 (.228)	330 (13.0)	24.4 (.960)	34.0 (1.34)
		F4	400	24.0 (.945)	24.0 (.945)	6.6 (.260)	330 (13.0)	24.4 (.960)	34.0 (1.34)

millimeters (inches)

# Film Chip Capacitors



## Standardized Range PEN (CF--7)

### DESCRIPTION

Use of PEN (polyethylene naphthalate) as dielectric.

New range available in six “standardized” \*case sizes.

### CAPACITANCE AND VOLTAGE RANGE

millimeters (inches)

DC Rated Voltage (105°C / 125°C)									
Capacitance	63 V / 47 V		100 V / 75 V		160 V / 120 V		250 V / 187 V		Capacitance Code
	Case Code	H max	Case Code	H max	Case Code	H max	Case Code	H max	
1 nF	03	1.5 (.059)	03	1.5 (.059)	03	1.5 (.059)	03	1.5 (.059)	0102
1.5	03	1.5 (.059)	03	1.5 (.059)	03	1.5 (.059)	03	1.5 (.059)	0152
2.2	03	1.5 (.059)	03	1.5 (.059)	03	1.5 (.059)	03	1.5 (.059)	0222
3.3	03	1.5 (.059)	03	1.5 (.059)	03	1.5 (.059)	03	1.5 (.059)	0332
4.7	03	1.5 (.059)	03	1.5 (.059)	03	1.5 (.059)	03	1.5 (.059)	0472
6.8	03	1.5 (.059)	03	1.5 (.059)	03	1.5 (.059)	03	1.5 (.059)	0682
10	03	1.5 (.059)	03	1.5 (.059)	03	2.0 (.079)	03	2.0 (.079)	0103
15	03	1.5 (.059)	03	1.5 (.059)	03	2.0 (.079)	03	2.0 (.079)	0153
22	03	1.5 (.059)	03	1.5 (.059)	03	2.5 (.098)	04	2.4 (.094)	0223
33	03	1.5 (.059)	03	1.5 (.059)	03	3.1 (.122)	04	2.4 (.094)	0333
47	03	2.0 (.079)	03	2.0 (.079)	04	2.4 (.094)	04	2.4 (.094)	0473
68	03	2.0 (.079)	03	2.0 (.079)	04	3.0 (.118)	04	3.0 (.118)	0683
100	03	2.0 (.079)	03	3.1 (.122)	04	3.5 (.138)	05	4.0 (.157)	0104
150	03	2.5 (.098)	04	2.4 (.094)	05	4.0 (.157)	05	4.0 (.157)	0154
220	03	3.1 (.122)	04	3.0 (.118)	05	4.0 (.157)	16	4.0 (.157)	0224
330	04	2.4 (.094)	04	4.0 (.157)	16	4.0 (.157)	16	4.8 (.189)	0334
470	04	3.5 (.138)	05	4.0 (.157)	17	3.8 (.150)	17	5.0 (.197)	0474
680	04	4.5 (.177)	05	5.0 (.197)	17	3.8 (.150)	18	4.4 (.173)	0684
1 μF	05	4.0 (.157)	16	4.8 (.189)	18	4.4 (.173)	18	5.0 (.197)	0105
1.5	17	5.5 (.217)	17	5.5 (.217)	18	5.0 (.197)			0155
2.2	17	6.2 (.244)	17	6.2 (.244)					0225
3.3	18	5.7 (.224)	18	7.5 (.295)					0335
4.7	18	7.5 (.295)	18	7.5 (.295)					0475

millimeters (inches)

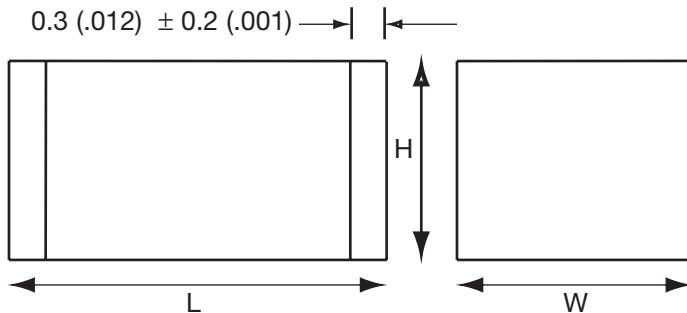

Case Code	Equivalent Size	L	W
03	1812	4.5 ± 0.5 (.177±.020)	3.2 ± 0.5 (.126±.020)
04	2220	5.7 ± 0.5 (.224±.020)	5.0 ± 0.5 (.197±.020)
05	2824	7.1 ± 0.5 (.280±.020)	6.1 ± 0.5 (.240±.020)
16	4030	10.2 ± 0.6 (.402±.024)	7.6 ± 0.8 (.299±.031)
17	5040	12.7 ± 0.6 (.500±.024)	10.2 ± 0.8 (.402±.031)
18	6054	15.2 ± 0.6 (.598±.024)	13.7 ± 0.8 (.540±.031)

\* “Standardized Range”: Range available from several film capacitors suppliers.

# Film Chip Capacitors

## Standardized Range PEN (CF--7)



### ELECTRICAL CHARACTERISTICS (TYPICAL VALUES)

#### CAPACITANCE

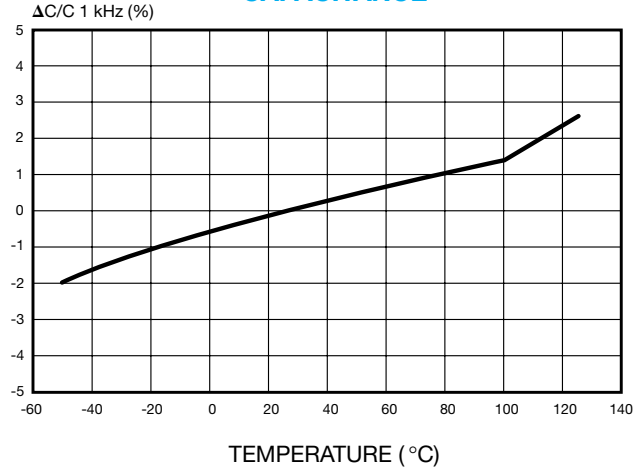

#### DISSIPATION FACTOR

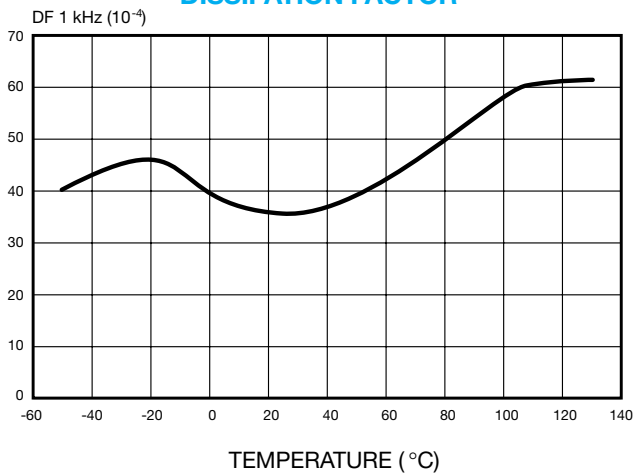

#### INSULATION RESISTANCE

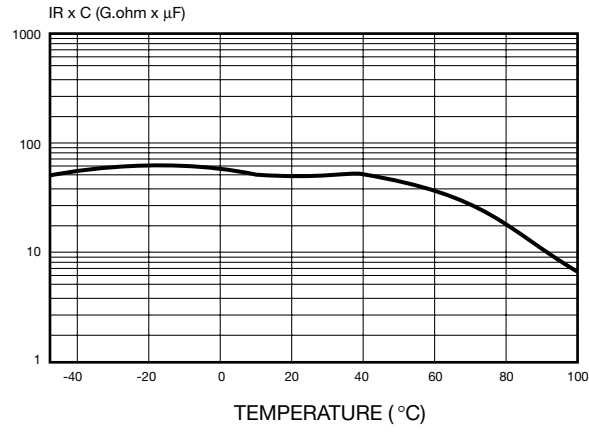

Minimum Insulation Resistance at 20°C	
$C \leq 0.33 \mu\text{F}$	$C > 0.33 \mu\text{F}$
IR > 1000 M $\Omega$	IR.C > 400 sec

Measuring conditions: the insulation resistance value is measured 1 minute after a voltage of 10 V for  $U_r < 100$  V and 100 V for  $U_r \geq 100$  V has been applied between terminations.

# Film Chip Capacitors

## Standardized Range PEN (CF--7)



### FREQUENCY CHARACTERISTICS (TYPICAL VALUES)

#### CAPACITANCE

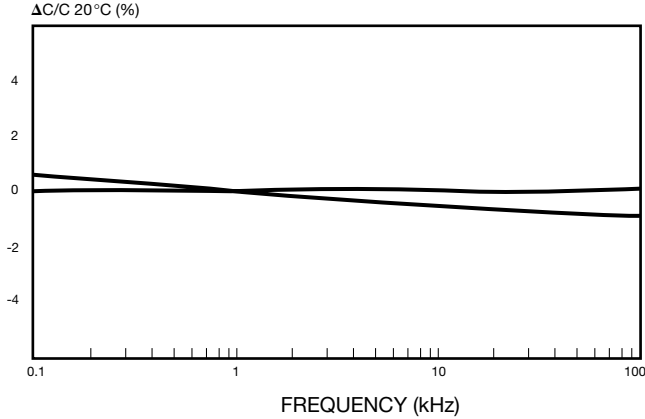

#### DISSIPATION FACTOR

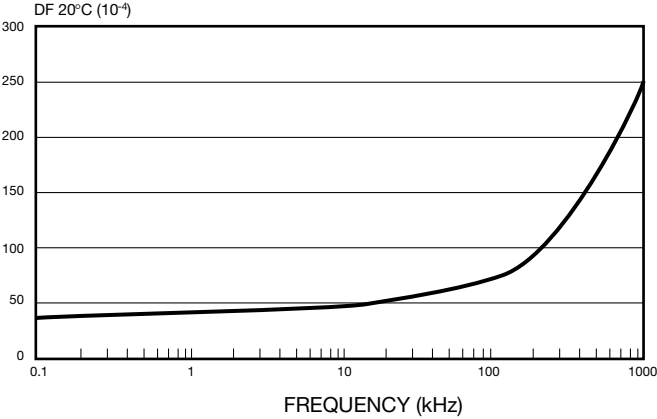

#### IMPEDANCE

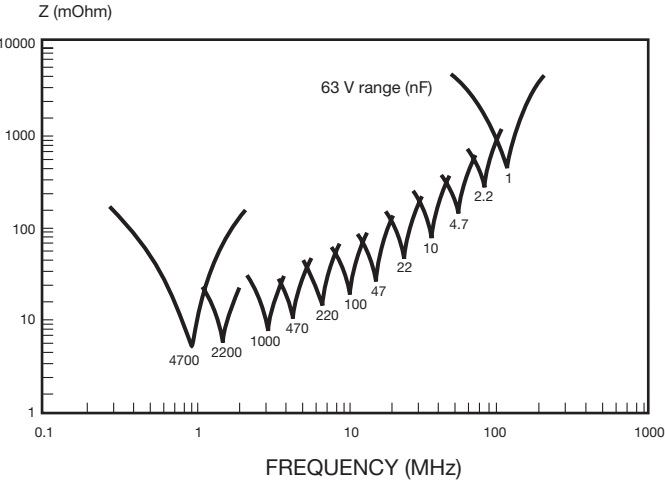

**TPC**

# Film Chip Capacitors



## Standardized Range PEN (CF--7)

### PACKAGING

The CF Series is available in bulk or tape and reel for automatic insertion.

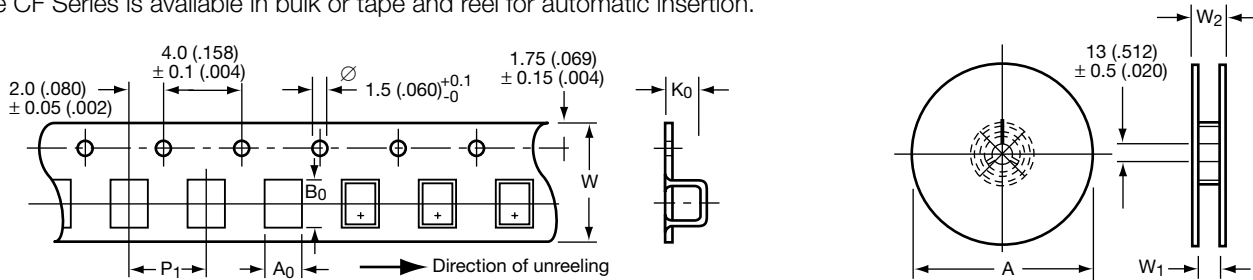

### TAPE AND REEL PACKAGING CODES

Capacitance	Packaging Codes				Capacitance code
	Rated Voltage				
	63 V	100 V	160 V	250 V	
1 to 6.8 nF	A1	A1	A1	A1	0102-0682
10	A1	A1	A2	A2	0103
15	A1	A1	A2	A2	0153
22	A1	A1	A3	B1	0223
33	A1	A1	A4	B1	0333
47	A2	A2	B1	B1	0473
68	A2	A2	B2	B2	0683
100	A2	A4	B3	C1	0104
150	A3	B1	C1	C1	0154
220	A4	B2	C1	D1	0224
330	B1	B4	D1	D2	0334
470	B3	C1	E1	E2	0474
680	B5	C2	E1	F1	0684
1 µF	C1	D2	F1	F2	0105
1.5	E3	E3	F2		0155
2.2	E4	E4			0225
3.3	F3	F4			0335
4.7	F4	F4			0475

#### Tape and reel characteristics:

In accordance with IEC 286 and EIA 481  
Material used:

Carrier tape: Antistatic Polycarbonate.  
Cover tape: Polyester.  
Reel: Recyclable polyester or cardboard.

Parts in bulk or on reel are packed in hermetically sealed plastic bags.

(Recommendation: Once the bag is open the capacitors should be kept in a dry atmosphere until soldering).

### TAPE AND REEL CHARACTERISTICS AND PACKAGING QUANTITIES

Case size	Bulk Qty/bag	Reel tape pack code	Reel tape Qty/reel	Tape dimensions			Reel dimensions		
				W ± 0.3	P1 ± 0.1	Ko	A ± 2	W1 +2 -0	W2 max
1812	1500	A1	1500	12.0 (.472)	8.0 (.315)	1.6 (.063)	180 (7.09)	12.4 (.488)	18.4 (.724)
		A2	1200	12.0 (.472)	8.0 (.315)	2.1 (.083)	180 (7.09)	12.4 (.488)	18.4 (.724)
		A3	900	12.0 (.472)	8.0 (.315)	2.6 (.102)	180 (7.09)	12.4 (.488)	18.4 (.724)
		A4	700	12.0 (.472)	8.0 (.315)	3.2 (.126)	180 (7.09)	12.4 (.488)	18.4 (.724)
1812	1500	A1	5800	12.0 (.472)	8.0 (.315)	1.6 (.063)	330 (13.0)	12.4 (.488)	22.0 (.866)
		A2	4500	12.0 (.472)	8.0 (.315)	2.1 (.083)	330 (13.0)	12.4 (.488)	22.0 (.866)
		A3	3600	12.0 (.472)	8.0 (.315)	2.6 (.102)	330 (13.0)	12.4 (.488)	22.0 (.866)
		A4	2900	12.0 (.472)	8.0 (.315)	3.2 (.126)	330 (13.0)	12.4 (.488)	22.0 (.866)
2220	1500	B1	3800	12.0 (.472)	8.0 (.315)	2.5 (.098)	330 (13.0)	12.4 (.488)	22.0 (.866)
		B2	3000	12.0 (.472)	8.0 (.315)	3.1 (.122)	330 (13.0)	12.4 (.488)	22.0 (.866)
		B3	2600	12.0 (.472)	8.0 (.315)	3.6 (.142)	330 (13.0)	12.4 (.488)	22.0 (.866)
		B4	2300	12.0 (.472)	8.0 (.315)	4.1 (.161)	330 (13.0)	12.4 (.488)	22.0 (.866)
		B5	1900	12.0 (.472)	8.0 (.315)	4.6 (.181)	330 (13.0)	12.4 (.488)	22.0 (.866)
2824	1000	C1	2100	16.0 (.630)	8.0 (.315)	4.1 (.161)	330 (13.0)	16.4 (.646)	25.0 (.984)
		C2	1700	16.0 (.630)	8.0 (.315)	5.1 (.201)	330 (13.0)	16.4 (.646)	25.0 (.984)
4030	500	D1	1400	16.0 (.630)	12.0 (.472)	4.1 (.161)	330 (13.0)	16.4 (.646)	25.0 (.984)
		D2	1200	16.0 (.630)	12.0 (.472)	4.9 (.193)	330 (13.0)	16.4 (.646)	25.0 (.984)
5040	300	E1	1100	24.0 (.945)	16.0 (.630)	3.9 (.154)	330 (13.0)	24.4 (.960)	34.0 (1.34)
		E2	800	24.0 (.945)	16.0 (.630)	5.1 (.200)	330 (13.0)	24.4 (.960)	34.0 (1.34)
		E3	800	24.0 (.945)	16.0 (.630)	5.6 (.220)	330 (13.0)	24.4 (.960)	34.0 (1.34)
		E4	700	24.0 (.945)	16.0 (.630)	6.3 (.248)	330 (13.0)	24.4 (.960)	34.0 (1.34)
6054	300	F1	600	24.0 (.945)	24.0 (.945)	4.5 (.177)	330 (13.0)	24.4 (.960)	34.0 (1.34)
		F2	500	24.0 (.945)	24.0 (.945)	5.1 (.200)	330 (13.0)	24.4 (.960)	34.0 (1.34)
		F3	500	24.0 (.945)	24.0 (.945)	5.8 (.228)	330 (13.0)	24.4 (.960)	34.0 (1.34)
		F4	300	24.0 (.945)	24.0 (.945)	7.6 (.299)	330 (13.0)	24.4 (.960)	34.0 (1.34)

millimeters (inches)

# Film Chip Capacitors



## Standardized Range PET H.T. (CF--2) / PEN (CF--7)

### MOUNTING & SOLDERING

For infrared and vapor phase reflow soldering, the temperature profile below shows allowable time temperature combination. These capacitors are NOT suitable for wave soldering.

In case of hand soldering, the temperature of the soldering iron should not be above 250°C. Special care must be taken to avoid touching the capacitor body with the iron tip.

\* Pad dimensions in millimeters (inches)

Case Code	Case Size	millimeters (inches)		
		A	B	C
03	1812	4.0 (.157)	1.5 (.059)	3.5 (.138)
04	2220	5.9 (.232)	1.9 (.075)	4.5 (.177)
05	2824	7.0 (.276)	2.5 (.098)	5.7 (.224)
16	4030	8.6 (.339)	3.0 (.118)	8.0 (.315)
17	5040	11.2 (.441)	3.5 (.138)	10.3 (.406)
18	6054	14.6 (.575)	3.6 (.142)	12.6 (.496)

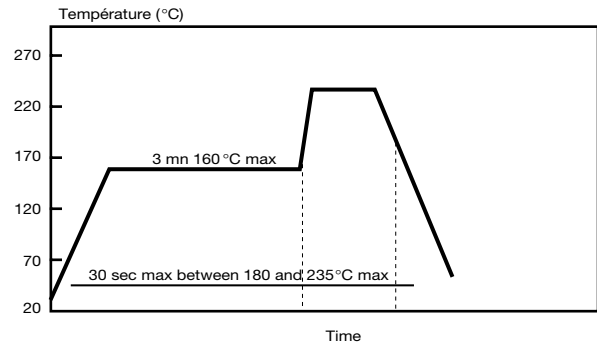
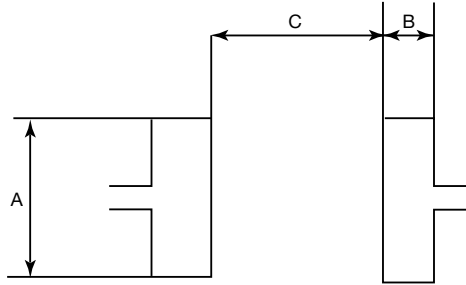

\* Recommended solder paste thickness

To allow optimum solderability, the recommended soldering paste thickness is for CF03 to CF05 : 150 to 200 µm  
CF16 to CF18 : 200 to 300 µm

### HOW TO ORDER

Example: 330 nF 63 V 5% case size 2220

<b>***</b>   Internal Code	<b>CF</b>   Type	<b>04</b>   Type Size 03: 1812 04: 2220 05: 2824 16: 4030 17: 5040 18: 6054	<b>7</b>   Dielectric Class 2: PET 7: PEN	<b>D</b>   Voltage 63 V: D 100 V: E 160 V: F 250 V: G	<b>0334</b>   Capacitance EIA Code * 1st digit: 0 (zero). * 2nd & 3rd: the 2nd significant figures of the capacitance value. * 4th digit: the number of zeros to be added to the capacitance value.	<b>J</b>   Tolerance 5%: J 10%: K	<b>--</b>   Suffix --: Bulk BA: Taped on reel ø 180 BC: Taped on reel ø 330
----------------------------------	------------------------	---	---	---	--	---	--

# Film Chip Capacitors



## Original Range (Non-Standardized) PEN (CF--7)

### DESCRIPTION

This original range of film chip capacitors uses a PEN (polyethylene naphthalate) film dielectric suitable for IR or vapor phase reflow soldering.

### CAPACITANCE AND VOLTAGE RANGE

millimeters (inches)

DC Rated Voltage (105°C / 125°C)									
Capacitance	63 V / 47 V		100 V / 75 V		160 V / 120 V		250 V / 187 V		Capacitance Code
	Case Code	H max	Case Code	H max	Case Code	H max	Case Code	H max	
1 nF	03	1.5 (.059)	03	1.5 (.059)	03	1.5 (.059)	03	1.5 (.059)	0102
1.5	03	1.5 (.059)	03	1.5 (.059)	03	1.5 (.059)	03	1.5 (.059)	0152
2.2	03	1.5 (.059)	03	1.5 (.059)	03	1.5 (.059)	03	1.5 (.059)	0222
3.3	03	1.5 (.059)	03	1.5 (.059)	03	1.5 (.059)	03	1.5 (.059)	0332
4.7	03	1.5 (.059)	03	1.5 (.059)	03	1.5 (.059)	03	1.5 (.059)	0472
6.8	03	1.5 (.059)	03	1.5 (.059)	03	1.5 (.059)	03	1.5 (.059)	0682
10	03	1.5 (.059)	03	1.5 (.059)	03	2.0 (.079)	03	2.0 (.079)	0103
15	03	1.5 (.059)	03	1.5 (.059)	03	2.0 (.079)	03	2.0 (.079)	0153
22	03	1.5 (.059)	03	1.5 (.059)	03	2.5 (.098)	04	2.4 (.094)	0223
33	03	1.5 (.059)	03	1.5 (.059)	03	3.1 (.122)	04	2.4 (.094)	0333
47	03	2.0 (.079)	03	2.0 (.079)	04	2.4 (.094)	04	2.4 (.094)	0473
68	03	2.0 (.079)	03	2.0 (.079)	04	3.0 (.118)	04	3.0 (.118)	0683
100	03	2.0 (.079)	03	3.1 (.122)	04	3.5 (.138)	05	4.0 (.157)	0104
150	03	2.5 (.098)	04	2.4 (.094)	05	4.0 (.157)	05	4.0 (.157)	0154
220	03	3.1 (.122)	04	3.0 (.118)	05	4.0 (.157)	06	2.8 (.110)	0224
330	04	2.4 (.094)	04	4.0 (.157)	06	4.7 (.185)	06	4.7 (.185)	0334
470	04	3.5 (.138)	05	4.0 (.157)	06	4.7 (.185)	06	4.7 (.185)	0474
680	04	4.5 (.177)	05	5.0 (.197)	07	5.6 (.220)	07	5.6 (.220)	0684
1 µF	05	4.0 (.157)	06	4.7 (.185)	08	4.4 (.173)	08	5.7 (.224)	0105
1.5	06	4.7 (.185)	06	4.7 (.185)	08	5.7 (.224)			0155
2.2	08	4.4 (.173)	08	4.4 (.173)					0225
3.3	08	5.7 (.224)	08	7.5 (.295)					0335
4.7	08	7.5 (.295)	08	7.5 (.295)					0475

millimeters (inches)

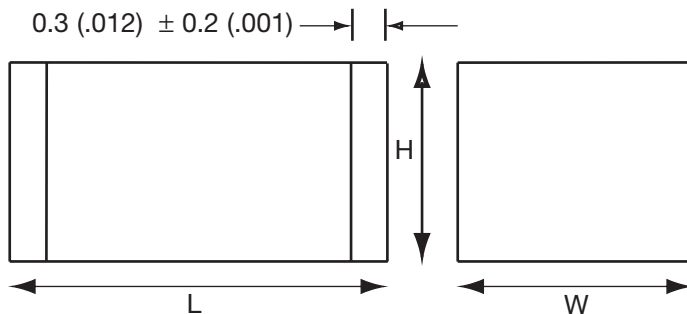

Case Code	Equivalent Size	L (mm)	W (mm)
03	1812	4.5 ± 0.5 (.177±.020)	3.2 ± 0.5 (.126±.020)
04	2220	5.7 ± 0.5 (.224±.020)	5.0 ± 0.5 (.197±.020)
05	2824	7.1 ± 0.5 (.280±.020)	6.1 ± 0.5 (.240±.020)
06	4540	11.4 ± 0.6 (.449±.024)	10.2 ± 0.8 (.402±.031)
07	5045	12.7 ± 0.6 (.500±.024)	11.4 ± 0.8 (.449±.031)
08	5460	13.7 ± 0.6 (.540±.024)	15.2 ± 0.9 (.598±.035)

# Film Chip Capacitors



## Original Range (Non-Standardized) PEN (CF--7)

### ELECTRICAL CHARACTERISTICS (TYPICAL VALUES)

#### CAPACITANCE

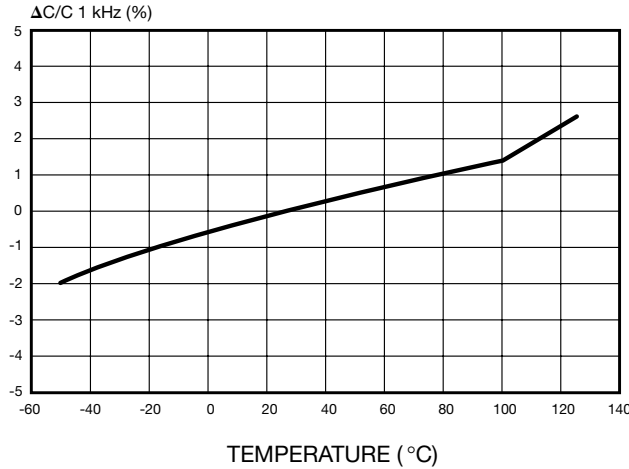

#### DISSIPATION FACTOR

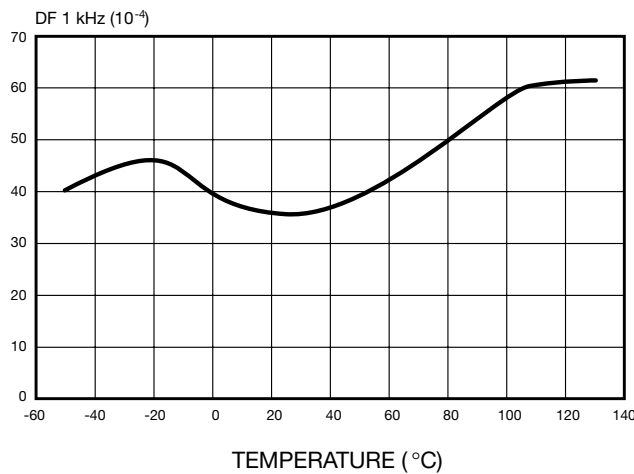

#### INSULATION RESISTANCE

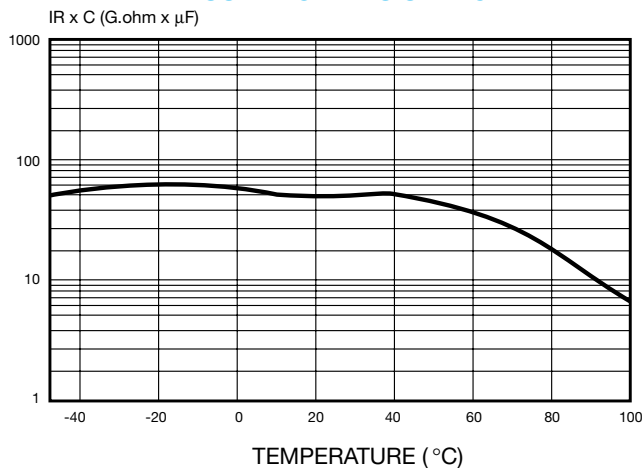

#### Minimum Insulation Resistance at 20°C

$C \leq 0.33 \mu F$	$C > 0.33 \mu F$
IR > 1000 M $\Omega$	IR.C > 400 sec

Measuring conditions: the insulation resistance value is measured 1 minute after a voltage of 10 V for  $U_r < 100$  V and 100 V for  $U_r \geq 100$  V has been applied between terminations.

# Film Chip Capacitors

Original Range (Non-Standardized) PEN (CF--7)



## FREQUENCY CHARACTERISTICS (TYPICAL VALUES)

### CAPACITANCE

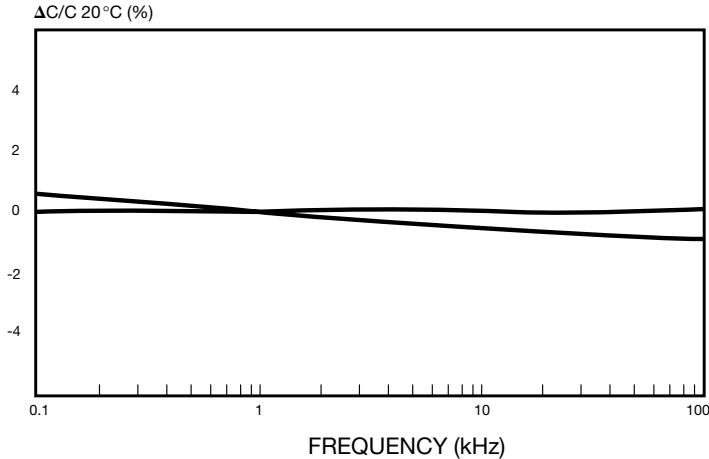

### DISSIPATION FACTOR

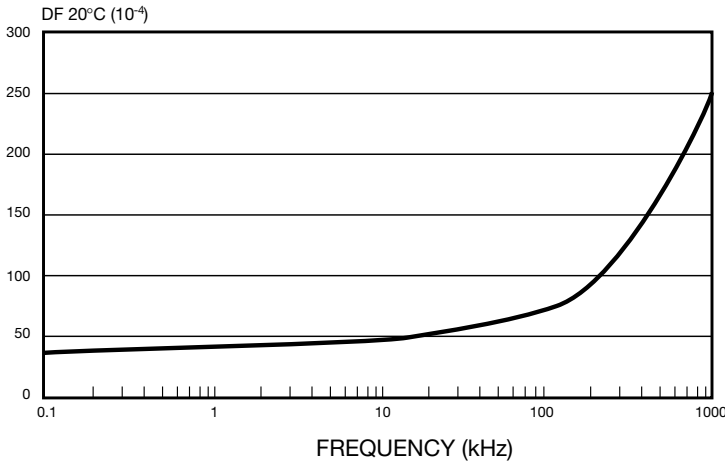

### IMPEDANCE

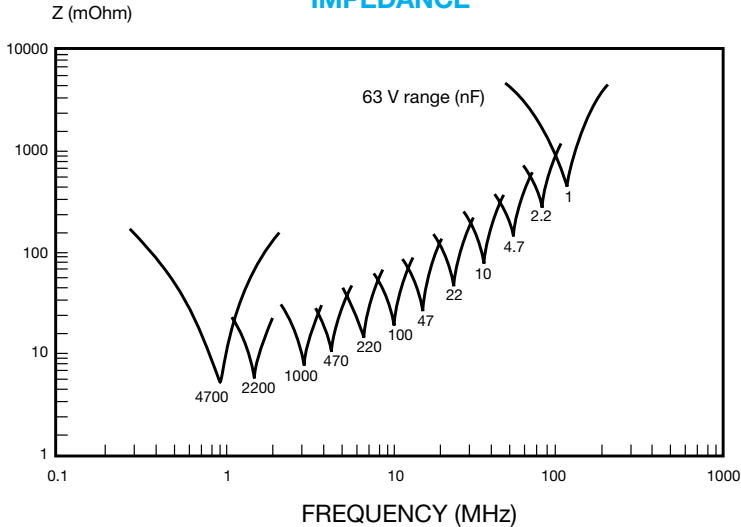

# Film Chip Capacitors



## Original Range (Non-Standardized) PEN (CF--7)

### PACKAGING

The CF Series is available in bulk or tape and reel for automatic insertion.

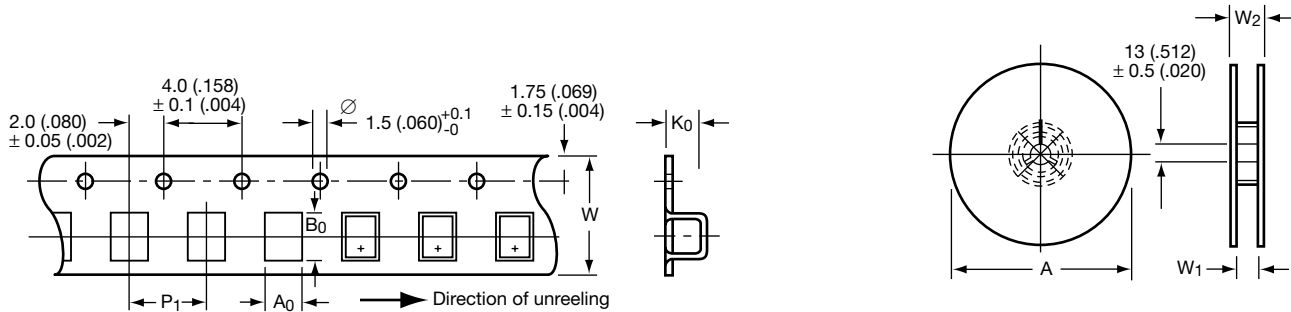

### TAPE AND REEL PACKAGING CODES

Packaging Codes					
Capacitance	Rated Voltage				Capacitance code
	63 V	100 V	160 V	250 V	
1 to 6.8 nF	A1	A1	A1	A1	0102-0682
10	A1	A1	A2	A2	0103
15	A1	A1	A2	A2	0153
22	A1	A1	A3	B1	0223
33	A1	A1	A4	B1	0333
47	A2	A2	B1	B1	0473
68	A2	A2	B2	B2	0683
100	A2	A4	B3	C1	0104
150	A3	B1	C1	C1	0154
220	A4	B2	C1	D1	0224
330	B1	B4	D2	D2	0334
470	B3	C1	D2	D2	0474
680	B5	C2	E1	E1	0684
1 µF	C1	D2	F1	F2	0105
1.5	D2	D2	F2		0155
2.2	F1	F1			0225
3.3	F2	F3			0335
4.7	F3	F3			0475

#### Tape and reel characteristics:

In accordance with IEC 286 and EIA 481  
Material used:

Carrier tape: Antistatic Polycarbonate.

Cover tape: Polyester.

Reel: Recyclable polyester or cardboard.

Parts in bulk or on reel are packed in hermetically sealed plastic bags.

(Recommendation: Once the bag is open the capacitors should be kept in a dry atmosphere until soldering).

### TAPE AND REEL CHARACTERISTICS AND PACKAGING QUANTITIES

Case size	Bulk Qty/bag	Reel tape pack code	Reel tape Qty/reel	Tape dimensions			Reel dimensions		
				W ± 0.3	P1 ± 0.1	Ko	A ± 2	W1 +2 -0	W2 max
1812	1500	A1	1500	12.0 (.472)	8.0 (.315)	1.6 (.063)	180 (7.09)	12.4 (.488)	18.4 (.724)
		A2	1200	12.0 (.472)	8.0 (.315)	2.1 (.083)	180 (7.09)	12.4 (.488)	18.4 (.724)
		A3	900	12.0 (.472)	8.0 (.315)	2.6 (.102)	180 (7.09)	12.4 (.488)	18.4 (.724)
		A4	700	12.0 (.472)	8.0 (.315)	3.2 (.126)	180 (7.09)	12.4 (.488)	18.4 (.724)
1812	1500	A1	5800	12.0 (.472)	8.0 (.315)	1.6 (.063)	330 (13.0)	12.4 (.488)	22.0 (.866)
		A2	4500	12.0 (.472)	8.0 (.315)	2.1 (.083)	330 (13.0)	12.4 (.488)	22.0 (.866)
		A3	3600	12.0 (.472)	8.0 (.315)	2.6 (.102)	330 (13.0)	12.4 (.488)	22.0 (.866)
		A4	2900	12.0 (.472)	8.0 (.315)	3.2 (.126)	330 (13.0)	12.4 (.488)	22.0 (.866)
2220	1500	B1	3800	12.0 (.472)	8.0 (.315)	2.5 (.098)	330 (13.0)	12.4 (.488)	22.0 (.866)
		B2	3000	12.0 (.472)	8.0 (.315)	3.1 (.122)	330 (13.0)	12.4 (.488)	22.0 (.866)
		B3	2600	12.0 (.472)	8.0 (.315)	3.6 (.142)	330 (13.0)	12.4 (.488)	22.0 (.866)
		B4	2300	12.0 (.472)	8.0 (.315)	4.1 (.161)	330 (13.0)	12.4 (.488)	22.0 (.866)
		B5	1900	12.0 (.472)	8.0 (.315)	4.6 (.181)	330 (13.0)	12.4 (.488)	22.0 (.866)
2824	1000	C1	2100	16.0 (.630)	8.0 (.315)	4.1 (.161)	330 (13.0)	16.4 (.646)	25.0 (.984)
		C2	1700	16.0 (.630)	8.0 (.315)	5.1 (.201)	330 (13.0)	16.4 (.646)	25.0 (.984)
4540	500	D1	1900	24.0 (.945)	12.0 (.472)	2.9 (.114)	330 (13.0)	24.4 (.960)	34.0 (1.34)
		D2	800	24.0 (.945)	16.0 (.630)	4.7 (.185)	330 (13.0)	24.4 (.960)	34.0 (1.34)
5045	300	E1	700	24.0 (.945)	16.0 (.630)	5.7 (.224)	330 (13.0)	24.4 (.960)	34.0 (1.34)
		F1	600	24.0 (.945)	24.0 (.945)	4.5 (.177)	330 (13.0)	24.4 (.960)	34.0 (1.34)
		F2	500	24.0 (.945)	24.0 (.945)	5.8 (.228)	330 (13.0)	24.4 (.960)	34.0 (1.34)
5460	300	F3	300	24.0 (.945)	24.0 (.945)	7.6 (.299)	330 (13.0)	24.4 (.960)	34.0 (1.34)

millimeters (inches)

# Film Chip Capacitors



## Original Range (Non-Standardized) PEN (CF--7)

### MOUNTING & SOLDERING

For infrared and vapor phase reflow soldering, the temperature profile below shows allowable time temperature combination. These capacitors are NOT suitable for wave soldering.

In case of hand soldering, the temperature of the soldering iron should not be above 250°C. Special care must be taken to avoid touching the capacitor body with the iron tip.

\* Pad dimensions in millimeters (inches)

millimeters (inches)

Case Size	A	B	C
1812	4.0 (.157)	1.5 (.059)	3.5 (.138)
2220	5.9 (.232)	1.9 (.075)	4.5 (.177)
2824	7.0 (.276)	2.5 (.098)	5.7 (.224)
4540	11.2 (.441)	3.1 (.122)	9.2 (.362)
5045	12.4 (.488)	3.5 (.138)	10.3 (.406)
5460	16.2 (.638)	3.6 (.142)	11.1 (.437)

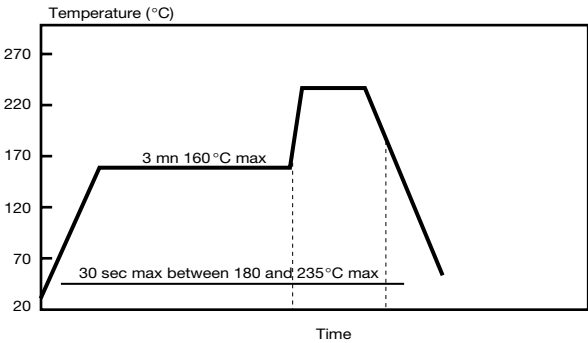
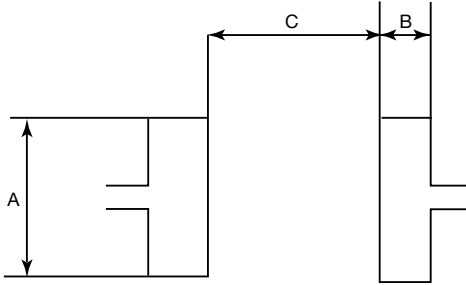

\* Recommended solder paste thickness

To allow optimum solderability, the recommended soldering paste thickness is for CF03 to CF05 : 150 to 200 µm  
CF06 to CF08 : 200 to 300 µm

### HOW TO ORDER

Example: 330 nF 63 V 5% case size 2220

\*\*\*

Internal Code

CF

Type

04

Type Size

- 03: 1812
- 04: 2220
- 05: 2824
- 06: 4540
- 07: 5045
- 08: 5460

7

Dielectric Class  
7: PEN

D

Voltage

- 63 V: D
- 100 V: E
- 160 V: F
- 250 V: G

0334

Capacitance EIA Code

- \* 1st digit: 0 (zero).
- \* 2nd & 3rd: the 2nd significant figures of the capacitance value.
- \* 4th digit: the number of zeros to be added to the capacitance value.

J

Tolerance

- 5%: J
- 10%: K

--

Suffix

- : Bulk
- BA: Taped on reel ø 180
- BC: Taped on reel ø 330

## USA

### AVX Myrtle Beach, SC Corporate Offices

Tel: 843-448-9411  
FAX: 843-448-1943

### AVX Northwest, WA

Tel: 360-669-8746  
FAX: 360-699-8751

### AVX North Central, IN

Tel: 317-848-7153  
FAX: 317-844-9314

### AVX Northeast, MA

Tel: 508-485-8114  
FAX: 508-485-8471

### AVX Mid-Pacific, CA

Tel: 408-436-5400  
FAX: 408-437-1500

### AVX Southwest, AZ

Tel: 602-539-1496  
FAX: 602-539-1501

### AVX South Central, TX

Tel: 972-669-1223  
FAX: 972-669-2090

### AVX Southeast, NC

Tel: 919-878-6357  
FAX: 919-878-6462

### AVX Canada

Tel: 905-564-8959  
FAX: 905-564-9728

## EUROPE

### AVX Limited, England European Headquarters

Tel: ++44 (0)1252 770000  
FAX: ++44 (0)1252 770001

### AVX S.A., France

Tel: ++33 (1) 69.18.46.00  
FAX: ++33 (1) 69.28.73.87

### AVX GmbH, Germany - AVX

Tel: ++49 (0) 8131 9004-0  
FAX: ++49 (0) 8131 9004-44

### AVX GmbH, Germany - Elco

Tel: ++49 (0) 2741 2990  
FAX: ++49 (0) 2741 299133

### AVX srl, Italy

Tel: ++39 (0)2 665 00116  
FAX: ++39 (0)2 614 2576

### AVX sro, Czech Republic

Tel: ++420 (0)467 558340  
FAX: ++420 (0)467 2844

## ASIA-PACIFIC

### AVX/Kyocera, Singapore Asia-Pacific Headquarters

Tel: (65) 258-2833  
FAX: (65) 350-4880

### AVX/Kyocera, Hong Kong

Tel: (852) 2-363-3303  
FAX: (852) 2-765-8185

### AVX/Kyocera, Korea

Tel: (82) 2-785-6504  
FAX: (82) 2-784-5411

### AVX/Kyocera, Taiwan

Tel: (886) 2-2516-7010  
FAX: (886) 2-2506-9774

### AVX/Kyocera, China

Tel: (86) 21-6249-0314-16  
FAX: (86) 21-6249-0313

### AVX/Kyocera, Malaysia

Tel: (60) 4-228-1190  
FAX: (60) 4-228-1196

### Elco, Japan

Tel: 045-943-2906  
FAX: 045-943-2910

### Kyocera, Japan

Tel: (81) 75-593-4518  
FAX: (81) 75-502-2705

### Contact:

